

PC70

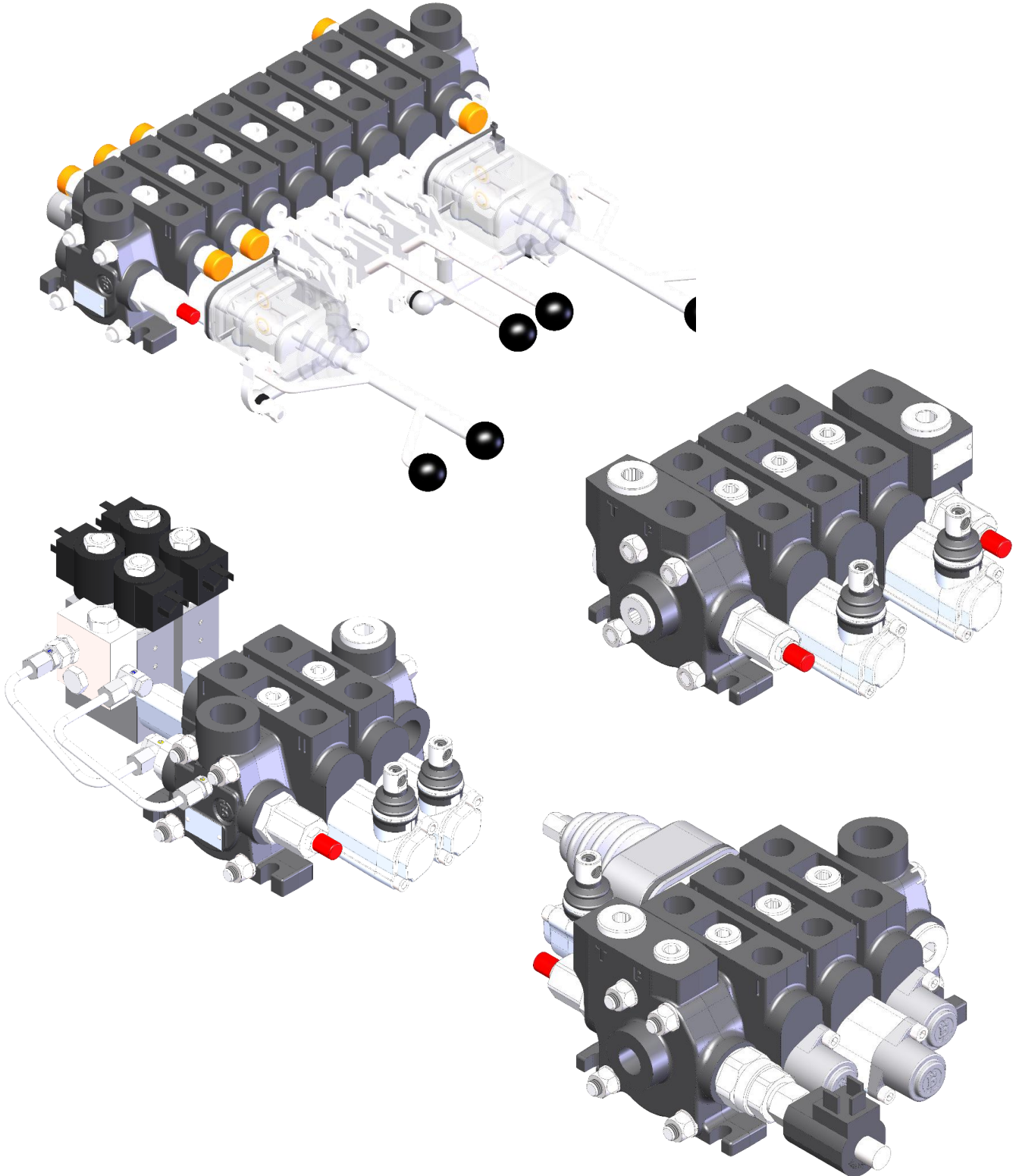

Features

Simple compact and heavy duty designed sectional valve from 1 to 10 sections for open and closed centre hydraulic systems.

- Fitted with a main pressure relief valve and a load check valve on each section
- Available with parallel and tandem circuits
- Optional power beyond port for parallel and tandem circuit
- Diameter 18 mm *0.71 in* interchangeable spools.
- A wide variety of options
- Actuation – manual, pneumatic, electro-pneumatic, hydraulic, electro-hydraulic, with flexible cables spool control kits.

Additional information

This catalogue shows the product in the most standard configuration. For special requests please contact sales.

WARNING!

All specifications of this catalogue refer to the standard product at this date. Badestnost, oriented in continuous improvement, reserves the right to discontinue, modify or revise specifications, without notice.

**BADESTNOST IS NOT RESPONSIBLE FOR ANY DAMAGE CAUSED BY AN
INCORRECT USE OF THE PRODUCT**

First edition 05-2026

Working conditions

Nominal flow rating		70 l/min	18.5 US gpm
Operating pressure (max.)	<i>parallel and tandem</i>	315 bar	4600 psi
Back pressure (max.)	<i>outlet port T, static</i>	35 bar	508 psi
Internal leakage (min.) A(B) to T	<i>Δp = 100 bar (1450 psi) fluid and valve at 40 °C (104 °F)</i>	8 cm ³ /min	0.48 in ³ /min
Hydraulic fluid		Mineral based oil	
Fluid temperature	<i>with NBR seals</i>	from -20 °C to 80 °C	<i>from -4 °F to 176 °F</i>
	<i>with FPM (Viton) seals</i>	from -20 °C to 100 °C	<i>from -4 °F to 212 °F</i>
Viscosity	<i>operating range</i>	from 15 to 75 mm ² /s	<i>from 15 to 75 cSt</i>
	<i>min.</i>	12 mm ² /s	12 cSt
	<i>max.</i>	400 mm ² /s	400 cSt
Permissible degree of fluid contamination		-/19/16 - ISO 4406	NAS 1683 - class 10
Ambient temperature	<i>with mechanical devices</i>	from -40 °C to 60 °C	<i>from -40 °F to 140 °F</i>
	<i>with pneumatic and hydraulic devices</i>	from -30 °C to 60 °C	<i>from -22 °F to 140 °F</i>
	<i>with electric devices</i>	from -20 °C to 50 °C	<i>from -4 °F to 140 °F</i>

Standard threads

Reference standard					
	BSP	UN-UNF	Metric	NPTF	
Thread	ISO 228/1	ISO 263	ISO 262	Ansi B1.20.3	
according to	BS 2779	ANSI B1.1 unified			
Cavity dimension	ISO 1179	11926	9974-1		
according to	SAE	J1926	J2244	J476a	
	DIN 3852-2 (Shape X or Y)		3852-1 (Shape X or Y)		
Port threadings and codes					
Codes:	G12	G34	G*	S8	S10
Main ports	BSP	BSP	BSP	UN-UNF	UN-UNF
Inlet P1, P2	G1/2-14	G3/4-14	G1/2-14	3/4-16 (SAE8)	7/8-14 (SAE10)
Outlet port T1	G3/4-14	G3/4-14	G3/4-14	1 1/16-12 (SAE12)	1 1/16-12 (SAE12)
Outlet port T2	G1/2-14	G3/4-14	G3/4-14	3/4-16 (SAE8)	7/8-14 (SAE10)
Outlet port T3	G3/4-14	G3/4-14	G3/4-14	1 1/16-12 (SAE12)	1 1/16-12 (SAE12)
Working ports, A and B	G1/2-14	G1/2-14	G1/2-14	3/4-16 (SAE8)	7/8-14 (SAE10)
Control pilot ports					
Pneumatic	1/8-27 NPTF	1/8-27 NPTF	1/8-27 NPTF	1/8-27 NPTF	1/8-27 NPTF
Hydraulic	G1/4-19	G1/4-19	G1/4-19	9/16-18 (SAE6)	9/16-18 (SAE6)

Dimensions

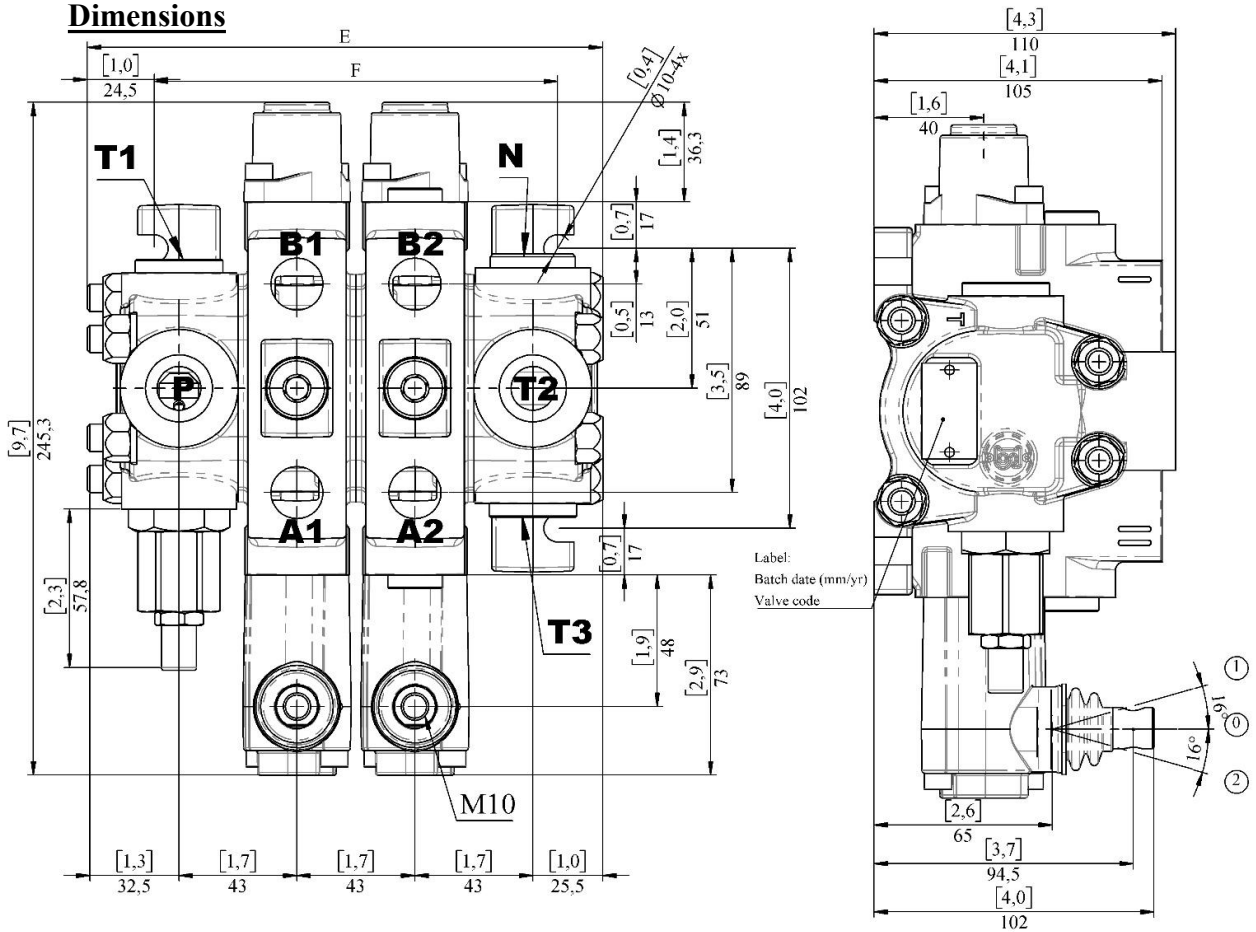

TYPE	E		F		Weight	
	mm	in	mm	in	kg	lb
PC70	145	5.71	104	4.09	6.80	15.0
2PC70	188	7.40	147	5.79	10.00	22.0
3PC70	231	9.09	190	7.48	13.20	29.1
4PC70	274	10.79	233	9.2	16.40	36.1
5PC70	317	12.5	276	10.9	19.60	43.2
6PC70	360	14.2	319	12.6	22.80	50.3

TYPE	E		F		Weight	
	mm	in	mm	in	kg	lb
7PC70	403	15.9	362	14.3	26.00	57.3
8PC70	446	17.6	405	15.9	29.20	64.4
9PC70	489	19.3	448	17.6	32.40	71.4
10PC70	532	20.9	491	19.3	35.60	78.5
11PC70	575	22.6	534	21.0	38.80	85.5
12PC70	618	24.3	577	22.7	42.00	92.6

Performance data

P->T pressure drop

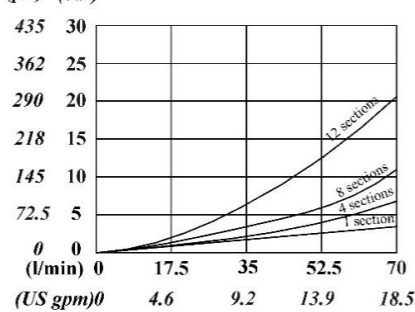

P-> A(B) pressure drop

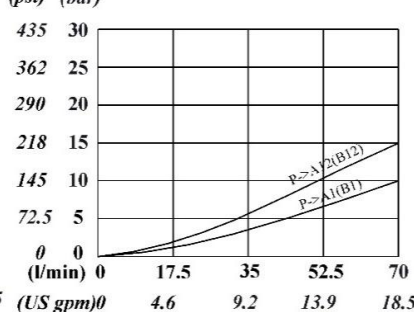

A(B)->T pressure drop

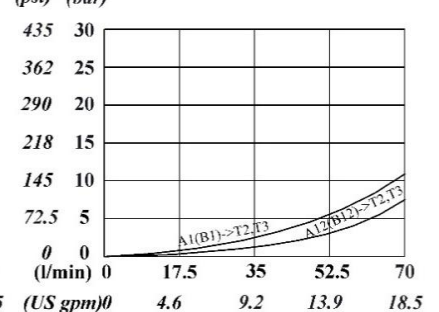

Hydraulic circuits

Parallel circuit

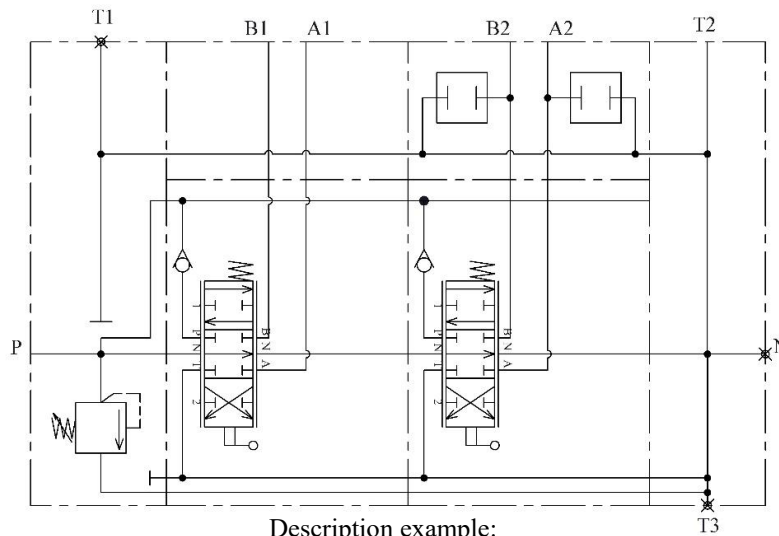

Description example:
2PC70/N2/PA1KZ1/PA1KZ1(AoBo)/T2-G34

Tandem circuit

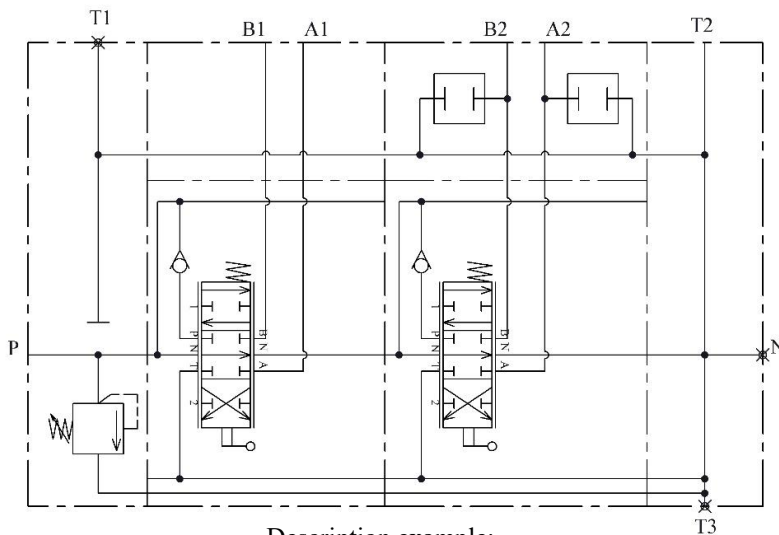

Description example:
2PC70/N2/TA1KZ1/TA1KZ1(AoBo)/T2-G34

Hydraulic circuits

Mixed circuit

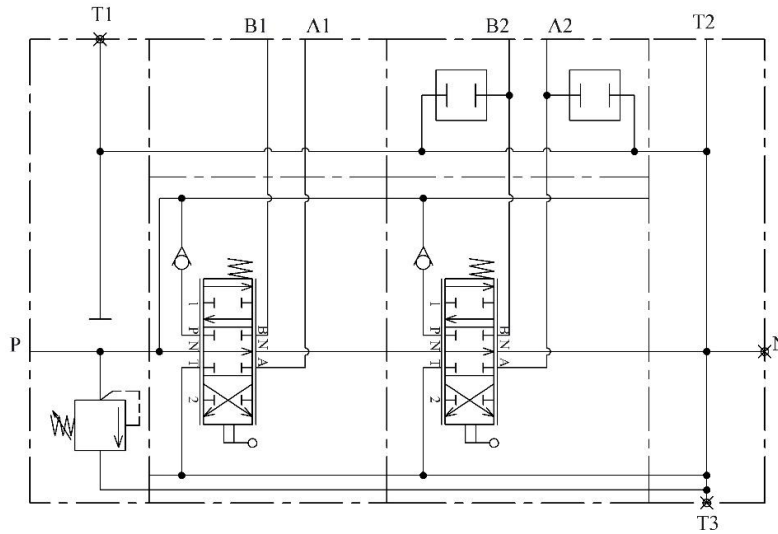

Description example:
2PC70/N2/TA1KZ1/PA1KZ1(AoBo)/T2-G34

Directional valve with right inlet

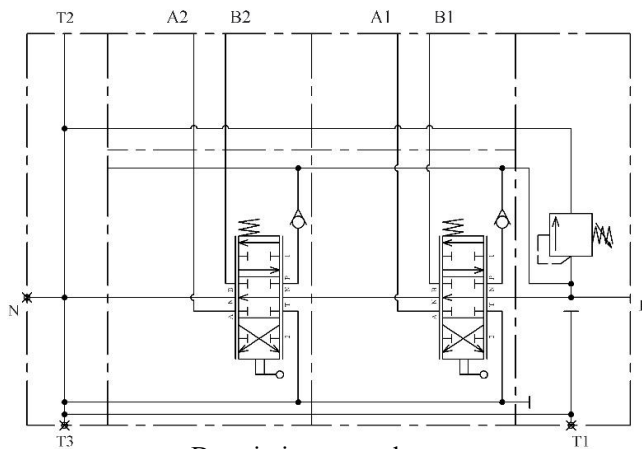
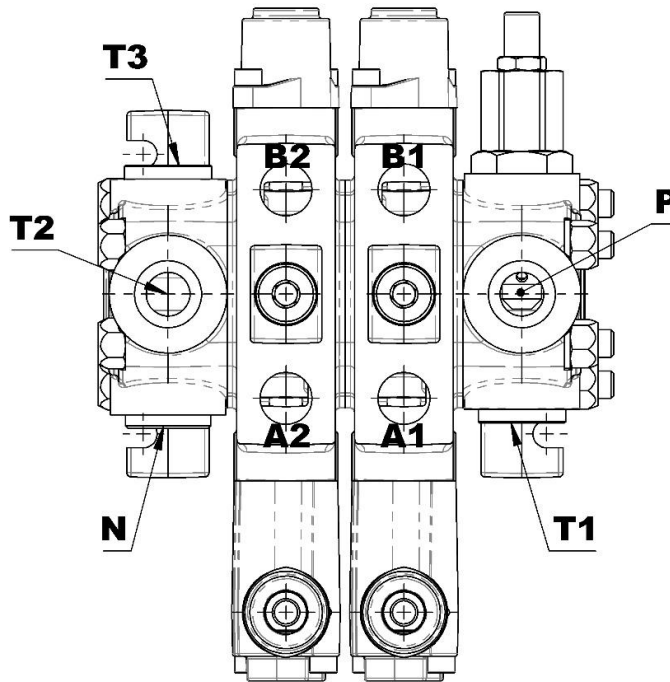

Description example:
2PC70/N2/2x(PRA1KZ1)/T2-G34

Order code, complete

*Following
sections*

First section

2PC70/N2/PA1KZ1/DF/PA1KZ1(AoBo)/T2-G-BP



*For identical sections use quantity of sections x (code of section),
e.g. 2x(PA1KZ1)...*

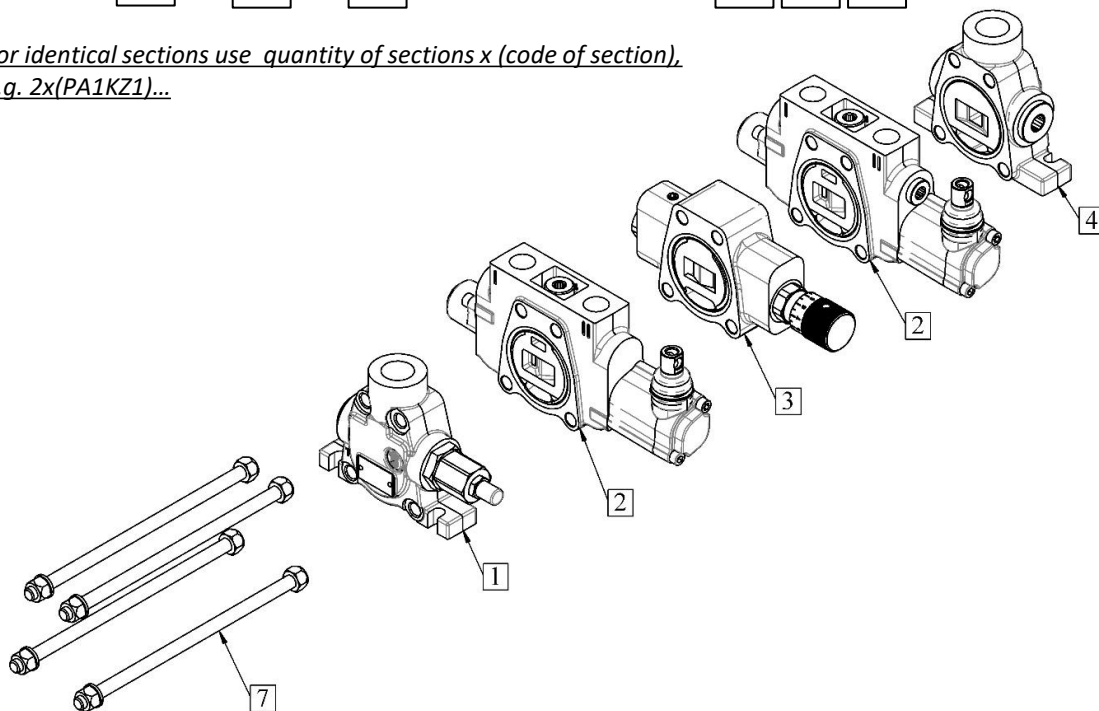

1 Complete inlet covers	
Type	Description
N1	Top inlet P and backside outlet port T1 with relief valve
N2	Top inlet P and backside outlet port T1 plugged with relief valve
L1	Side inlet P1 with relief valve for left inlet valves (standard)
L2	Top inlet with relief valve for left inlet valves (standard)
L3	Side inlet with relief valve for right inlet valves
L4	Top inlet with relief valve for right inlet valves

2 Complete working sections	
PA1KZ1	Parallel circuit, double acting spool with spring return and lever control
PA1KZ1(AoBo)	Parallel circuit, prearranged for port valves, double acting spool with spring return and lever control
TA1KZ1	Tandem circuit, double acting spool with spring return and lever control
TA1KZ1(AoBo)	Tandem circuit, prearranged for port valves, double acting spool with spring return and lever control

Order code, complete

3 Intermediate sections		5 Valve Threading - refer to page 3	
DF	<i>Pressure compensated flow divider section, excess flow goes to tank</i>	6 Coating and plating	
IM.C	<i>Intermediate inlet with relief valve, which combines the flow from the by-pass line of previous sections</i>	<i>Valve body is phosphated, steel parts Zn plated, spools either Ni, or Cr plating (omit in valve description)</i>	
IM.S	<i>Intermediate inlet with relief valve, which separates the flow from the by-pass line to tank.</i>	BP	Painting
CS1	<i>Intermediate outlet cover</i>	7 Assembly kit (tie rod kit)	
OM-C2T	<i>Intermediate outlet cover with high pressure carry over and outlet, to be used in combination with two inlet covers on both sides of the valve (N or L)</i>	1S	<i>Tie rod kit for 1 section</i>
OM-C2LC2R	<i>Intermediate outlet cover with two separate high pressure carry over lines, to be used in combination with two inlet covers N</i>	2S	<i>Tie rod kit for 2 section</i>
4 Complete outlet cover		3S	<i>Tie rod kit for 3 section</i>
T1	<i>Outlet cover ports (T2, T3) plugged, in use only inlet cover low pressure port T1, to be used in combination N1 only</i>	4S	<i>Tie rod kit for 4 section</i>
T2	<i>Outlet cover with top outlet T2</i>	5S	<i>Tie rod kit for 5 section</i>
T3	<i>Outlet cover with front outlet T3</i>	6S	<i>Tie rod kit for 6 section</i>
T3C2	<i>Back carry over port C2 with top port high pressure T2 (plugged) and front port low pressure T3</i>	7S	<i>Tie rod kit for 7 section</i>
T1C2	<i>Back carry over port C2 with top port high pressure T2 (plugged) and front port low pressure T3 (plugged), outlet port T1, to be used in combination with N1 only</i>	8S	<i>Tie rod kit for 8 section</i>
		9S	<i>Tie rod kit for 9 section</i>
		10S	<i>Tie rod kit for 10 section</i>

Directional control valve with two inlets

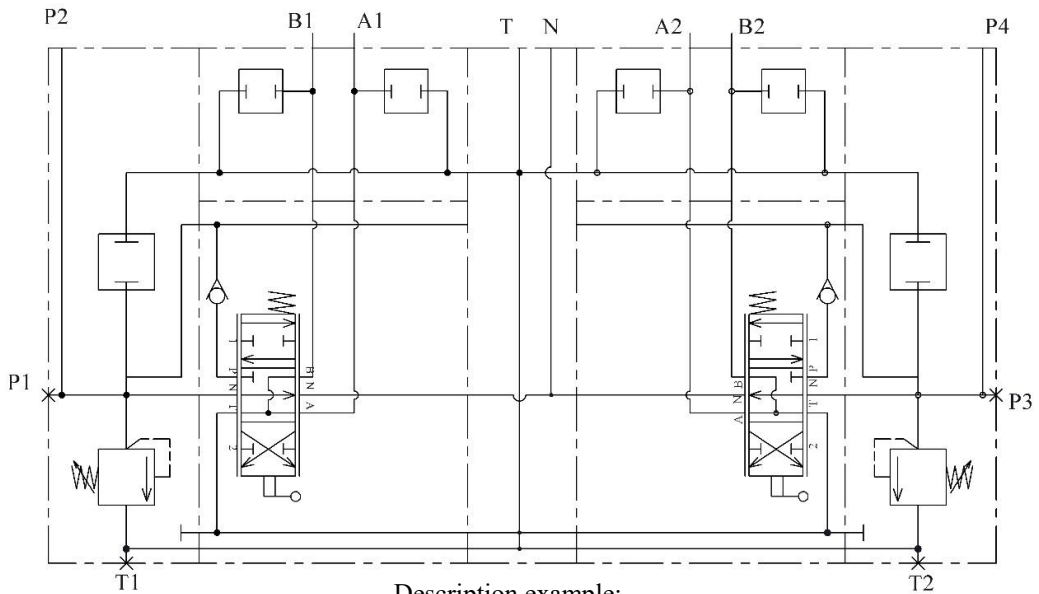
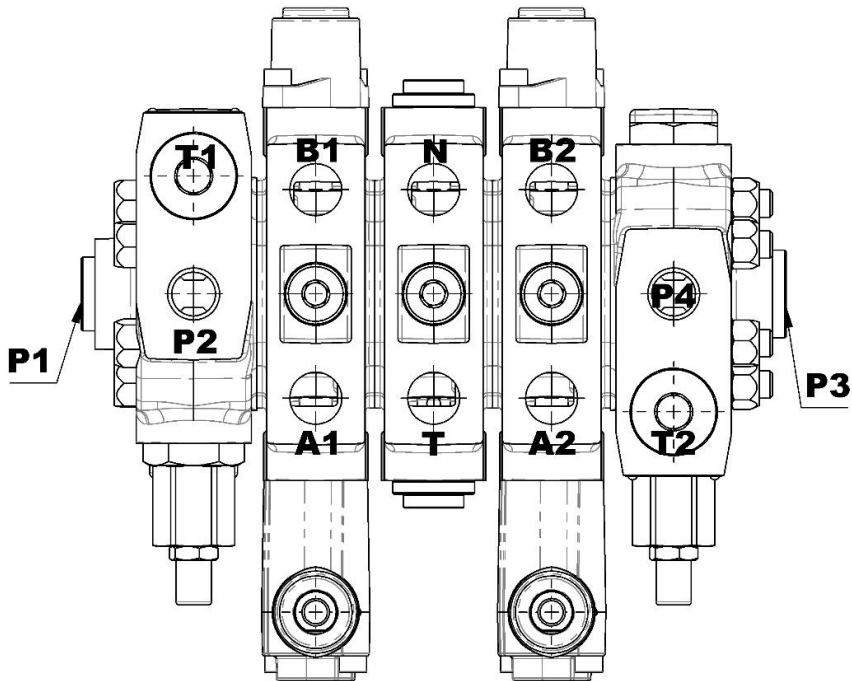

Description example:
2PC70/L2/PD1KZ1/OM.C2T/PRD1KZ1/L4-G34

Inlet cover, order code

L3 (250) (ELP) - 24V - G - Zn

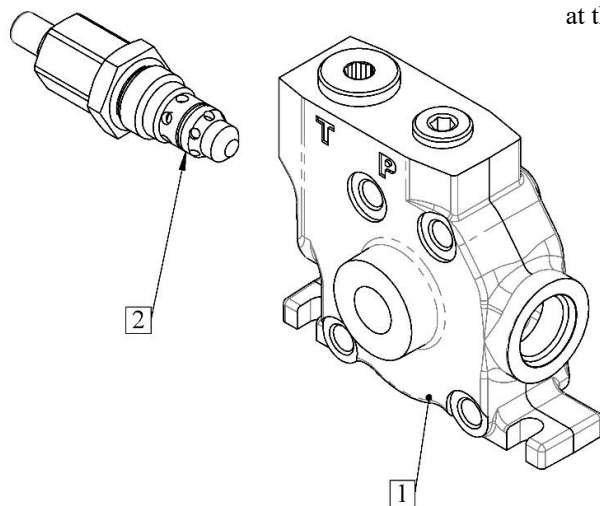
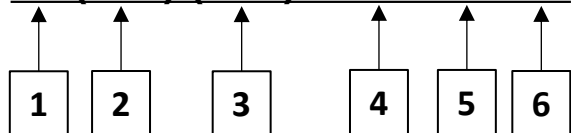

When inlet cover is part of a valve, the voltage (4), threading (5) and plating (6) go at the end of the valve description

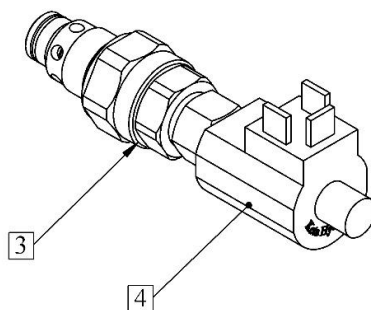

1 Inlet cover body

Type	Description
N1	Top inlet P and backside outlet port T1 with relief valve
N2	Top inlet P and backside outlet port T1 plugged with relief valve
L1	Side inlet P1 with relief valve for left inlet valves (standard)
L2	Top inlet with relief valve for left inlet valves (standard)
L3	Side inlet with relief valve for right inlet valves
L4	Top inlet with relief valve for right inlet valves

2 Relief valve option

omit	Range 50-315 bar / 725 to 4270 psi standard setting at 180 bar / 2610 psi
svp	Relief valve blanking plug

Standard setting is referred to 12 l/min flow, example for relief valve with a preset valve at 250 bar with cap nut for fixed setting (250-FV)

3 Unloader valve option

ELP	With screw emergency
-----	----------------------

4 Coil for unloader valve

12V	12V coil
24V	24V coil
12V(DT)	12V DT coil
24V(DT)	24V DT coil

5 Valve Threading - refer to page 3

6 Coating and plating

	Valve body is phosphated, steel parts Zn plated, spools either Ni, or Cr plating (omit in valve description)
BP	Painting

Inlet cover – type N

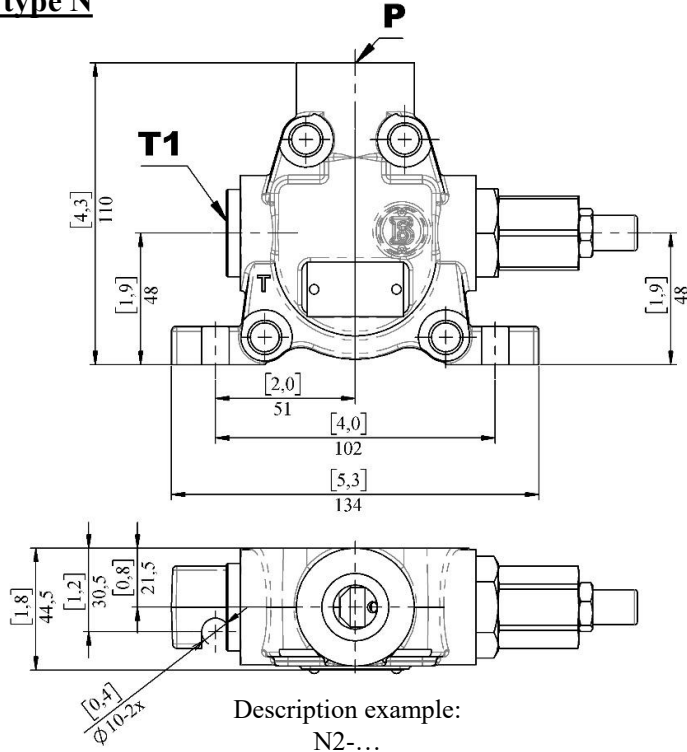

Inlet cover open tank port, to be used in combination with T1

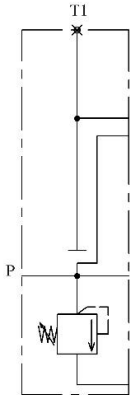
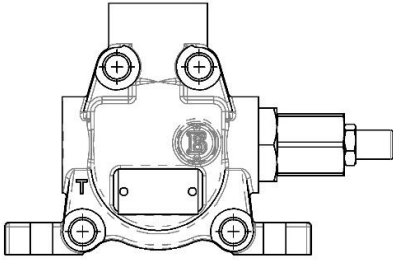
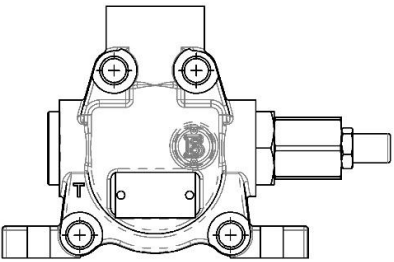

Description example:
N2-...

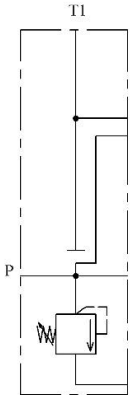

Description example:
N1-...

Order code for inlet cover L

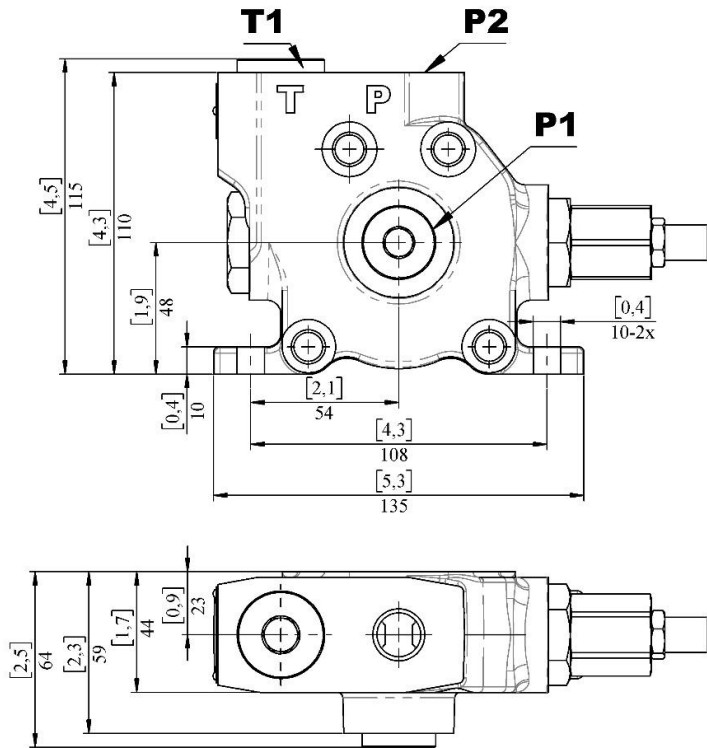

Inlet cover with top inlet and relief for left hand side configuration

Inlet cover with side inlet and relief for left hand side configuration

Inlet cover with top inlet and relief for right hand side configuration

Inlet cover with side inlet and relief for right hand side configuration

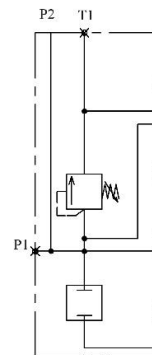
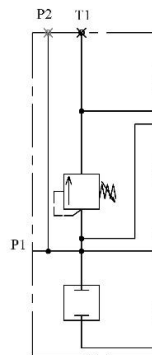
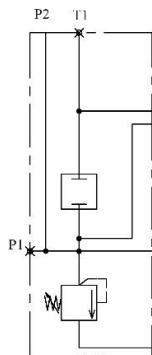
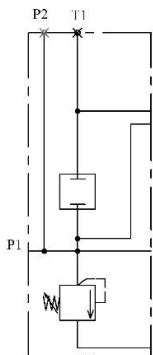
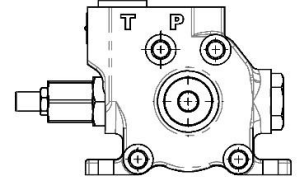
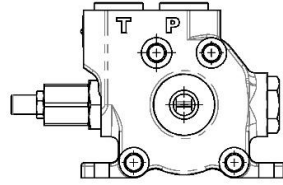
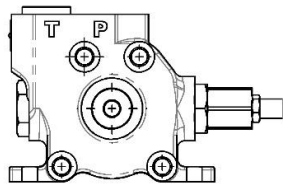
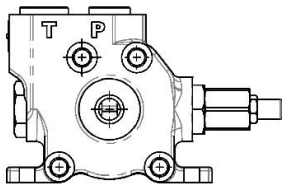

Description example:
L1-...

Description example:
L2-...

Description example:
L3-...

Description example:
L4-...

Inlet relief valve

(280 – FV)

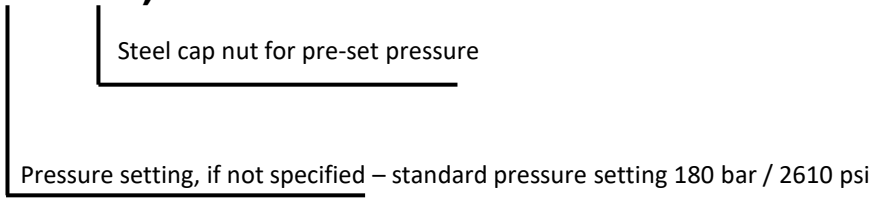

Standard main relief valve configuration

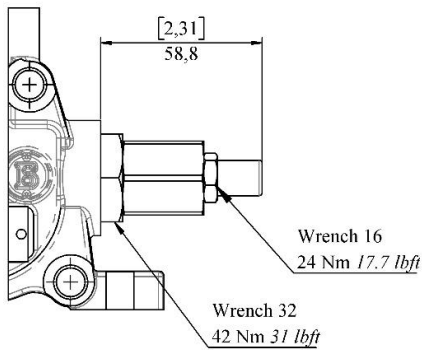

Valve setting range, with only one spring type

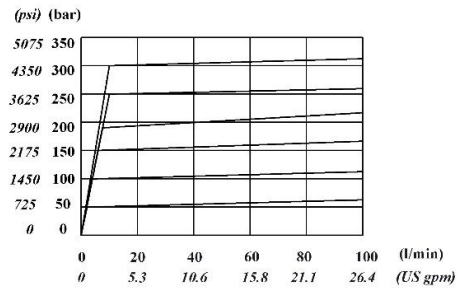

Main relief valve configuration with cap nut (FV)

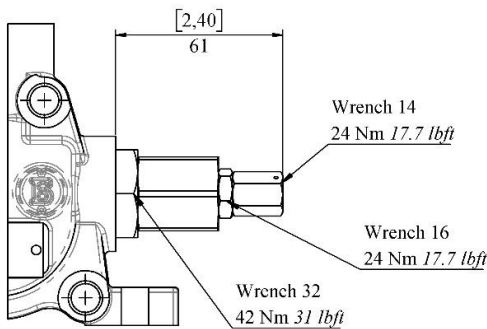

Time response

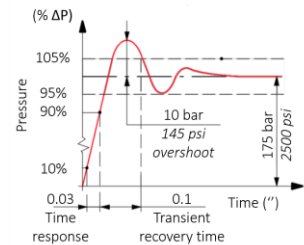

Without main relief valve – blanking plug only (svp)

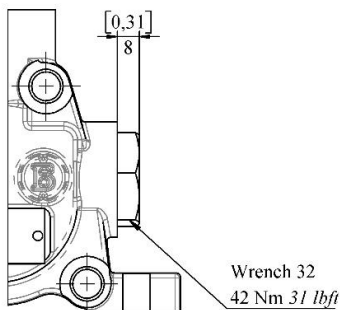

Unloader valve - ELP

Unloader valve can be used only with inlet cover type L

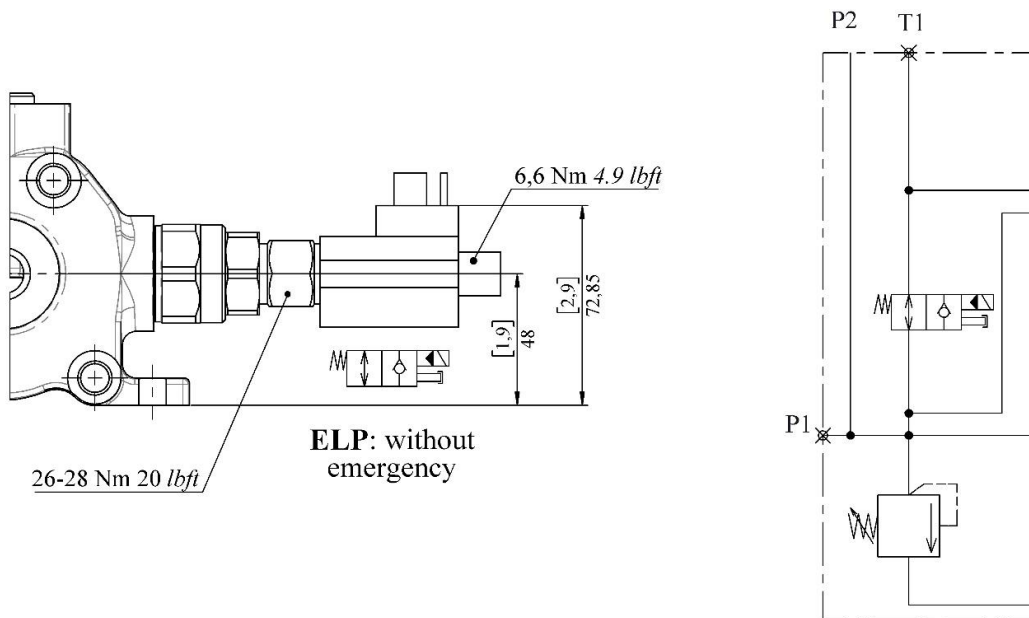

Features

- Nominal flow.....100 l/min 26.4 US gpm
- Max. pressure.....315 bar 4600 psi
- Internal leakage.....3 ccm/min @ 100 bar 0.18 cin/min @1450 psi

Pressure drop valve

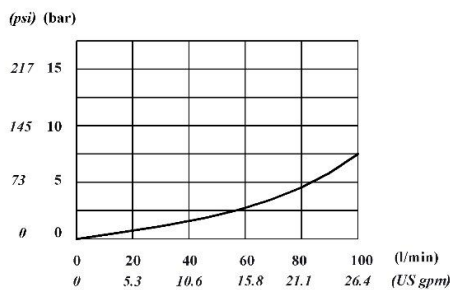

Connector specifications

2P+T according to
ISO 4400 / EN175301-803

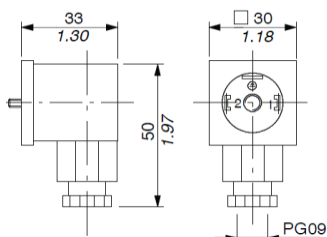

Sections, order code

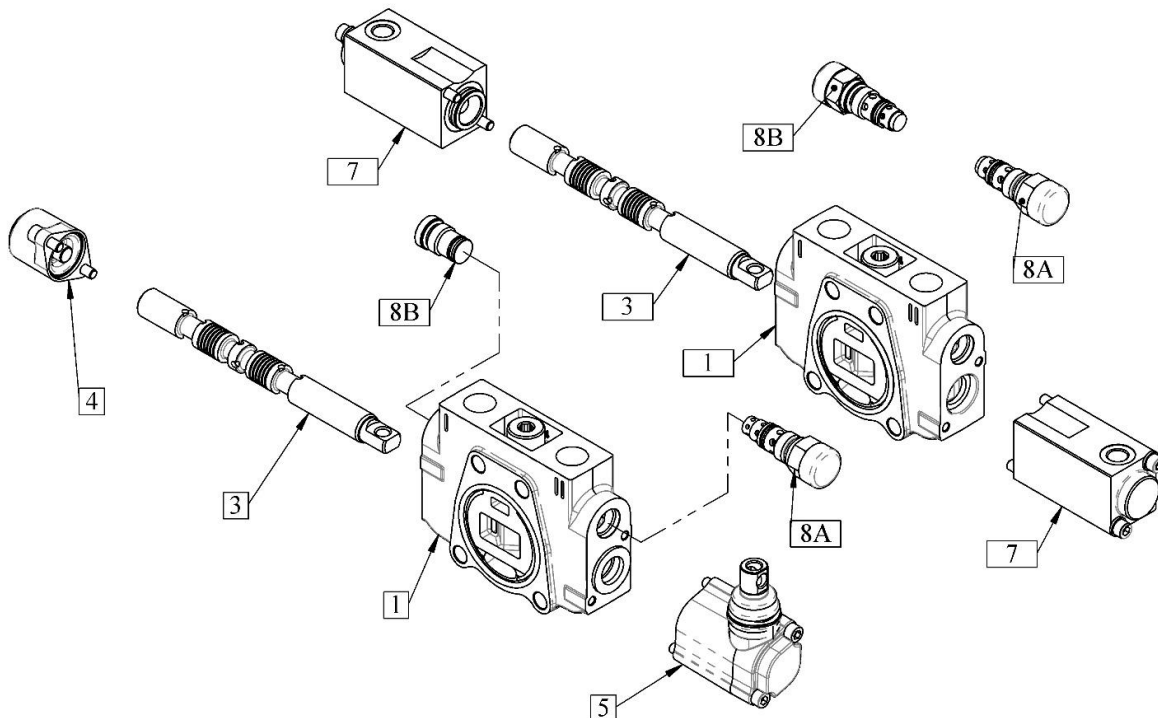
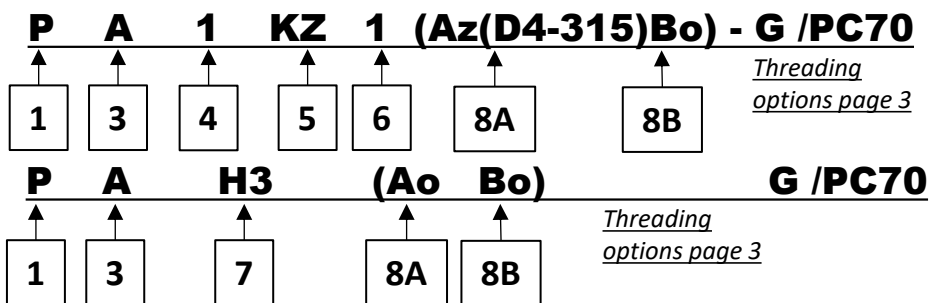

Sections, order code

1 Body type

Type	Description
P	Parallel body circuit
T	Tandem body circuit

If pos. 8 from the section description is missing the valve body kit does not have the required bores for auxiliary valves.

2 Position with respect to pump inlet

Type	Description
omit	Left hand configuraton, pump port is on the left-hand side with respect to the control
R	Right hand configuration, pump port is on the right-hand side with respect to the control

3 Spool options

Type	Description
A	Double acting, 3 position, with A and B closed in pos. 0
B	Single acting on A, 3 positions, B plugged, requires a plug.
C	Single acting on B, 3 positions, A plugged, requires a plug.
D	Double acting, 3 position, with A and B opened to tank in pos. 0
E	Double acting, 3 position, B opened to tank in pos. 0
F	Double acting, 3 position, A opened to tank in pos. 0

4 Spool positioners (side B)

Type	Description
1	With spring return in pos. 0
1C	With spring return in pos. 0, soft spring
1Z	With spring return in pos. 0 and pin with M8 male thread for dual control
1rAB	With spring return in pos. 0 and stroke adjustments both directions
1E	With spring return in pos. 0 and microswitch included
1D(M8)	With spring return in pos 0 and pin with M8 female thread for dual control
1T	With spring return in pos. 0 with teton (push piston)
14	Spring return in pos. 0, no microswitch kit included

4	2 positions, with spring return in pos. 0 from pos. 2
5	2 positions, with spring return in pos. 0 from pos. 1
6	2 positions, with spring return in pos. 1 from pos. 2
7	2 positions, with spring return in pos. 2 from pos. 1
7Z	2 positions, with spring return in pos. 2 from pos. 1 and pin with M8 male thread for dual control
7T	2 positions, with spring return in pos. 2 from pos. 1 with teton (push piston)
7D(M8)	2 positions, with spring return in pos. 2 from pos. 1, and pin with M8 female thread for dual control
7zS1	2 positions, with spring return in pos. 2 from pos. 1 with special tie rod kit M8 for dual control
8	Detent in positions 0, 1 and 2
8Z	Detent in positions 0, 1 and 2, and pin with M8 male thread for dual control
8F	Friction detent with infinite positions limit with pos. 0, 1 and 2
9	Detent in positions 1 and 0
10	Detent in positions 0 and 2
11	Detent in positions 1 and 2
11B	Detent in positions 1 and 2, and spring return to pos. 0
2	With detent in position 1 and spring return in pos. 0
3	With detent in position 2 and spring return in pos. 0
3D(M8)	With detent in position 2 and spring return in pos. 0 and pin with M8 female thread for dual control
6B3	2 positions, with spring return in pos. 2 from pos. 1 with detent in pos. 2
7B2	2 positions, with spring return in pos. 1 from pos. 2 with detent in pos. 1
1V2	With spring return in pos. 0 for flexible cable control
8V2	Detent in positions 0, 1 and 2 for flexible cable control
1H	Proportional hydraulic control- single side
1P	ON/OFF pneumatic control
1EP	ON/OFF electro-pneumatic control
1ED3	ON/OFF electro-hydraulic control
Particular positioner kits for special spools	

Sections, order code

5	Spool controls (side A)
	<i>without lever box, with plate</i>
KZ	<i>Lever box for M10</i>
KZe	<i>Lever box for M10, extreme conditions</i>
KZT	<i>Lever box for M8 with teton (push piston)</i>
KI	<i>Lever box, collet type, horizontal $\varnothing 9$ mm</i>
KY	<i>Lever box, collet type, vertical $\varnothing 9$ mm</i>
<i>Adding a 0 after the first part of the code will make the execution rotated 180°, lever will face the bottom of the valve, not the ports eg. KZ0</i>	
KZV	<i>Safety lever box, vertical configuration</i>
KZH	<i>Safety lever box, horizontal configuration</i>
SLP	<i>without lever box with dustproof plate</i>
V1	<i>Flexible cable connection</i>
ju+1	<i>Joystick lever for 2 sections with pivot 1 o'clock</i>
ju+2	<i>Joystick lever for 2 sections with pivot at 11 o'clock</i>
ju+3	<i>Joystick lever for 2 sections with pivot 7 o'clock</i>
ju+4	<i>Joystick lever for 2 sections with pivot at 5 o'clock</i>
<i>Optional ball type handle (jb+...), and custom lengths</i>	
6	Handle options
1	<i>M10x170</i>
<i>Custom lengths and bends available</i>	
7	Complete controls
H3	<i>Dual side proportional hydraulic control</i>
H3a	<i>Dual side proportional hydraulic control with stroke adjustment</i>
8	Auxiliary (Port) relief valves
omit	<i>Valve body without pre-machined bores for auxiliary valves.</i>
o	<i>Relief valve blanking plug</i>
x	<i>Anti-cavitation valve</i>
Anti-shock valve	
y(D2-120)	<i>Range 50-120 bar / 725 to 1740 psi standard setting at 120 bar / 1740 psi</i>
y(120-250)	<i>Range 120-250 bar / 1740 to 3625 psi setting other than 180 bar / 2610 psi</i>
y(D4-220)	<i>Range 220-315 bar / 3190 to 4570 psi standard setting at 220 bar / 3190 psi</i>
Anti-shock and anti-cavitation valve	
z(D2-120)	<i>Range 50-120 bar / 725 to 1740 psi standard setting at 120 bar / 1740 psi</i>
z(120-250)	<i>Range 120-250 bar / 1740 to 3625 psi setting other than 180 bar / 2610 psi</i>
z(D4-220)	<i>Range 220-315 bar / 3190 to 4570 psi standard setting at 220 bar / 3190 psi</i>
(FV)	<i>Fixed valve setting and sealing</i>

Sections, dimension data and circuit

P-type section (parallel)
Section with port valve arrangement
(Dimensions are same for P, T, and S)

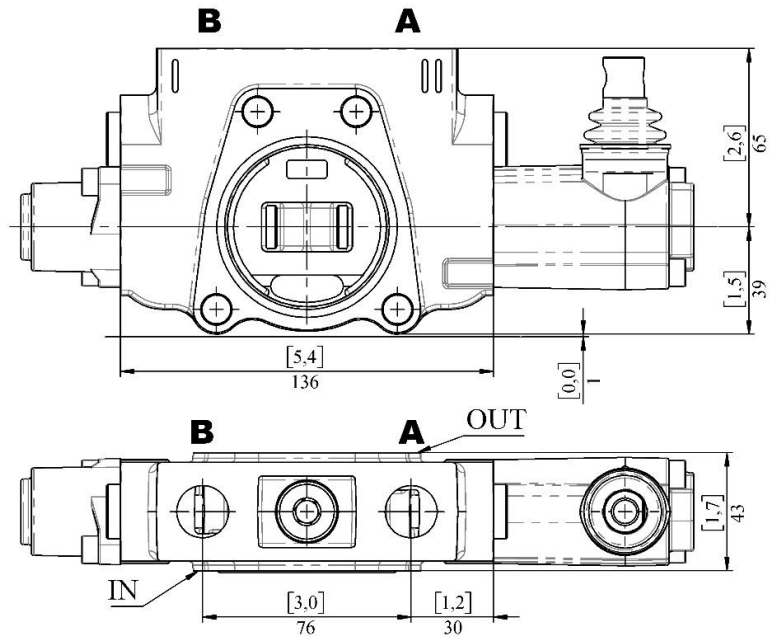

P-type section (parallel)
Section without port valve arrangement
(Dimensions are same for P, T, and S)

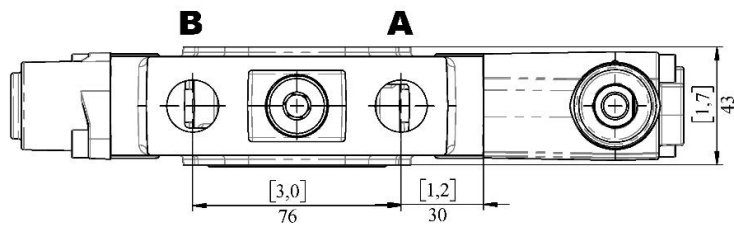

P-type
(with port relief)

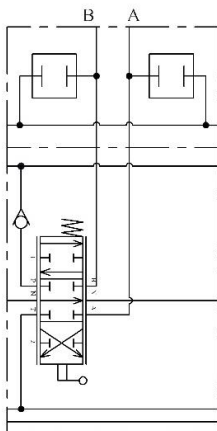

T-type
(with port relief)

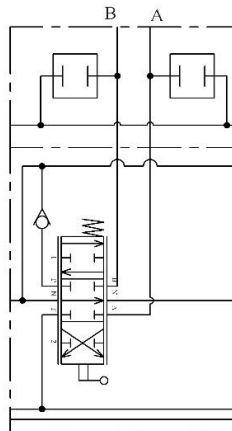

P-type
(without port relief)

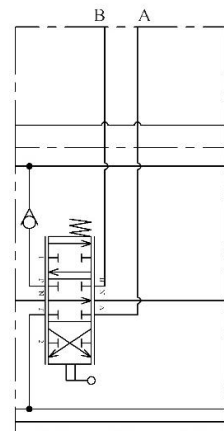

Spool types

All spools have the ends shown in the drawing below. These ends are necessary to join the spool to the controls on side A and positioners on side B.

Sectional valves are symmetric – so all spools are left and right version “R”, depending on the direction in which the spool is installed.

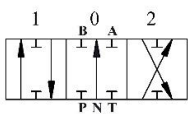
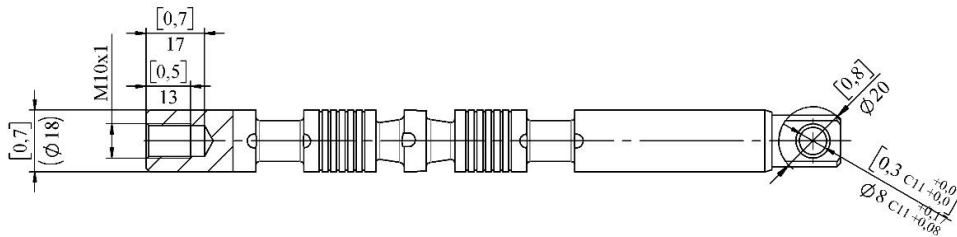
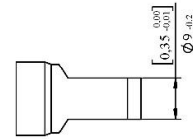

A Double acting spool, work ports closed in neutral position.

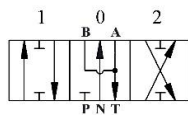
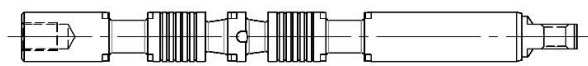

D Double acting spool, work ports open to tank in neutral position.

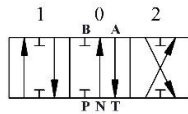
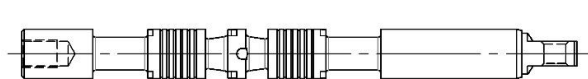

E Double acting spool, work port B open to tank in neutral position.

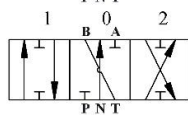
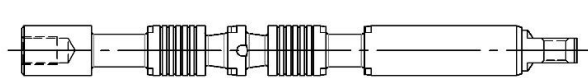

F Double acting spool, work port A open to tank in neutral position.

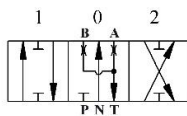
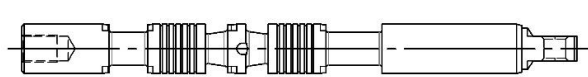

Dd Double acting spool, closed center, work ports partially open to tank

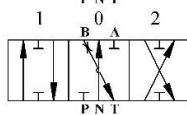
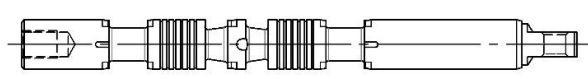

Ed Double acting spool, closed center, work port B partially open to tank

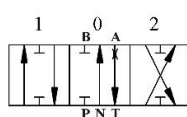
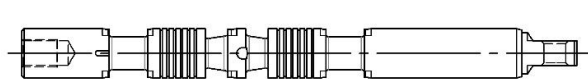

Fd Double acting spool, closed center, work port A partially open to tank

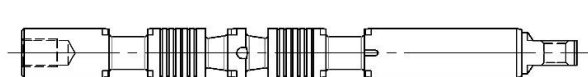

Spool types

Spools for single-acting cylinders:

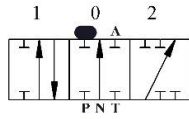

Single acting on A, 3
position, B plugged

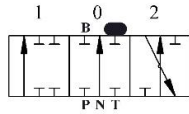
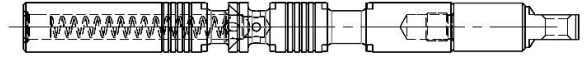

Single acting on B, 3
positions, A plugged



Spool positioner (B-side)

Kit 1

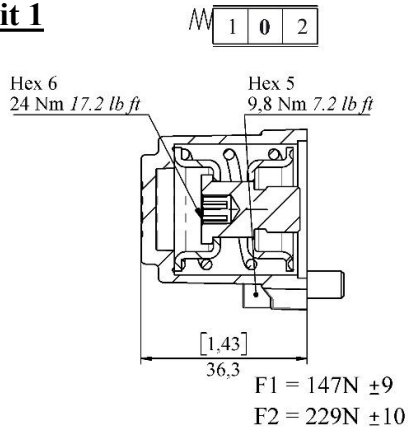

Kit 1C

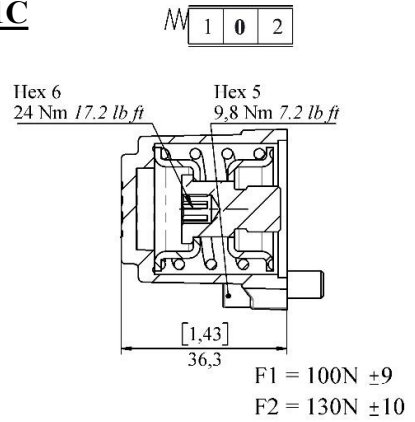

Kit 1Z

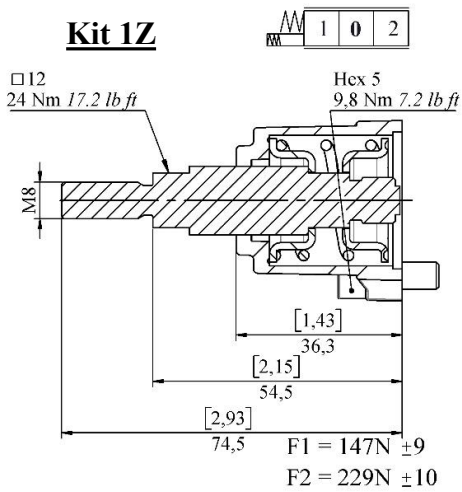

Kit 1T

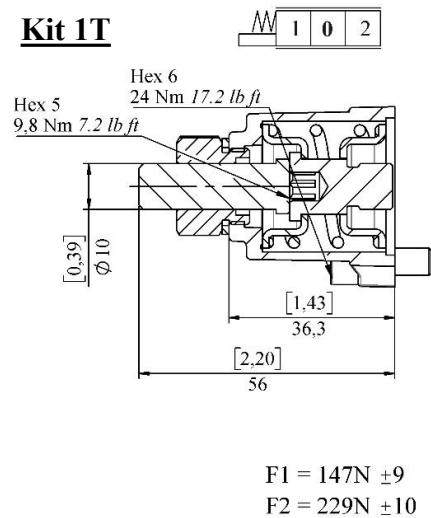

Kit 1D(M8)

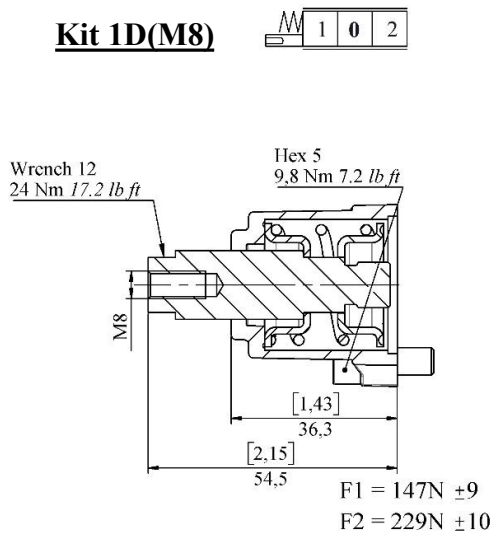

Kit 1rAB

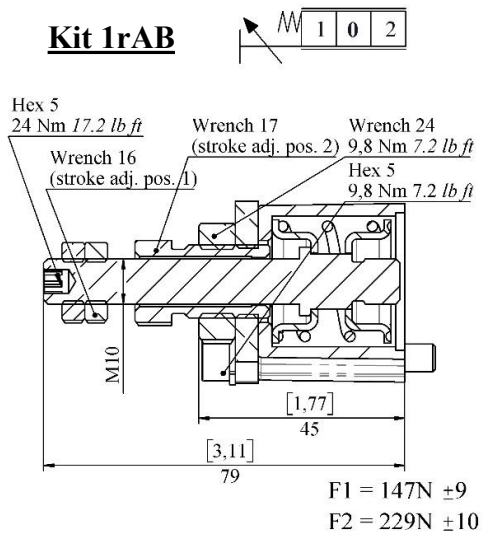

Spool positioner (B-side)

Kit 4

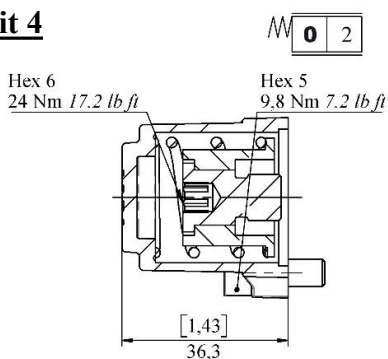

Kit 5

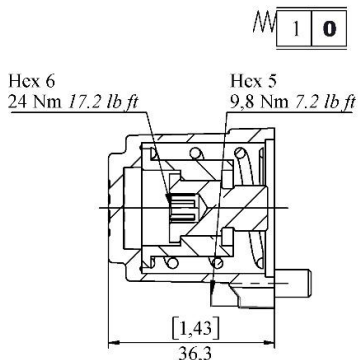

Kit 6

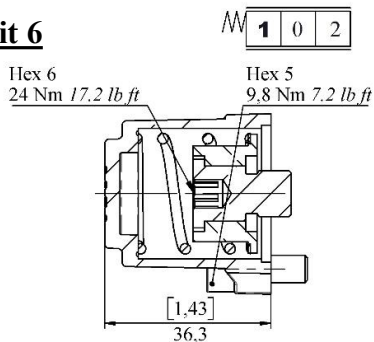

Kit 7

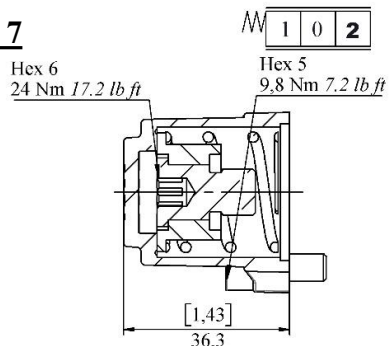

Kit 7T

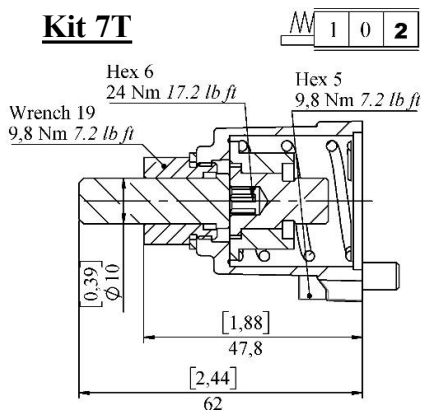

Kit 7D(M8)

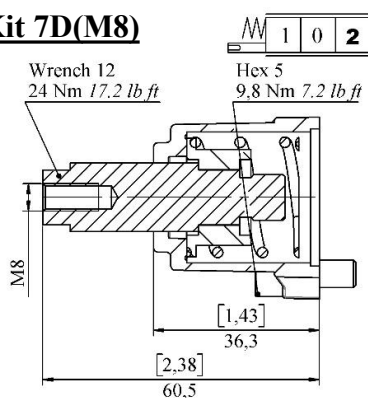

Spool positioners (B-side)

Kit 7Z

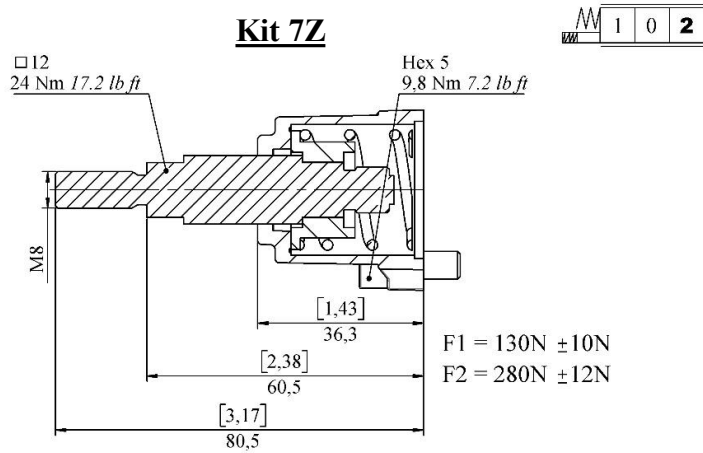

Kit 7zS1

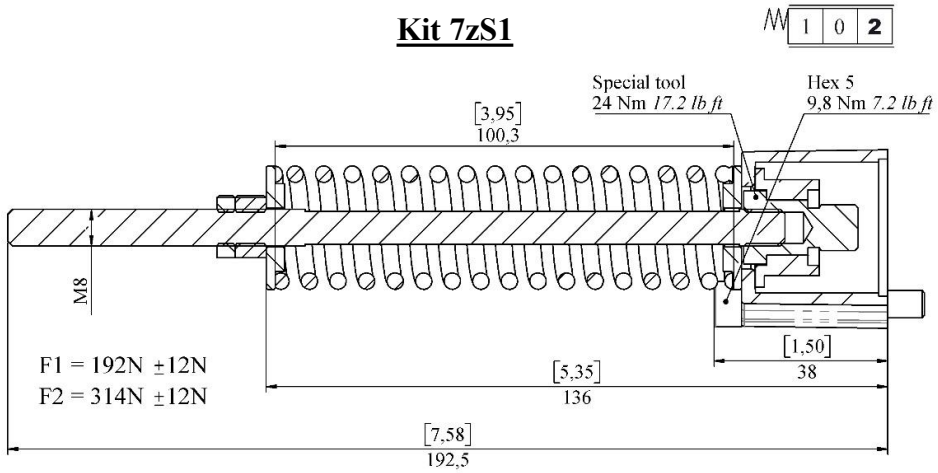

Kit 6B3

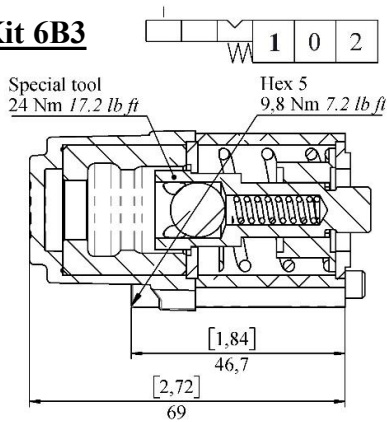

Kit 7B2

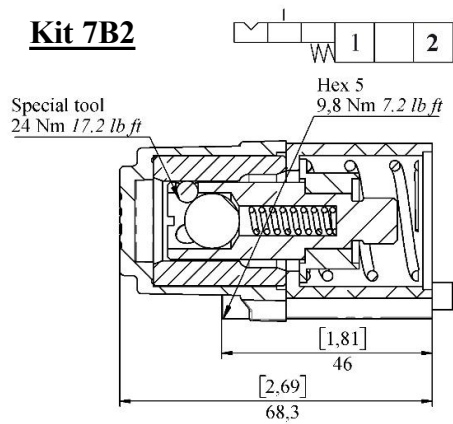

Spool positioners (B-side)

Kit 8

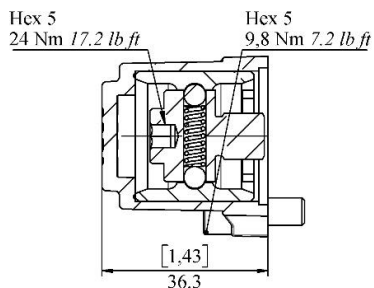
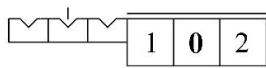

Kit 8Z

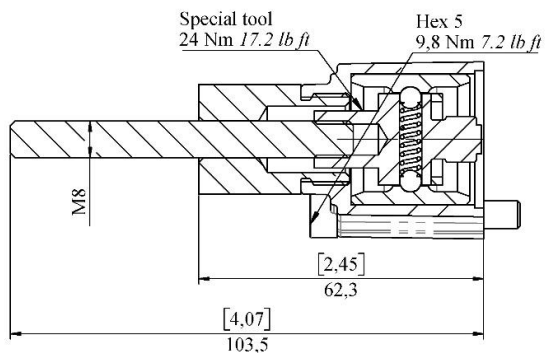
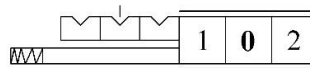

Kit 9

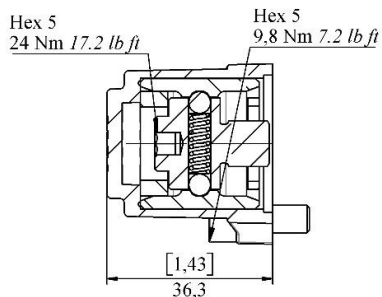
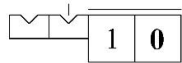

Kit 10

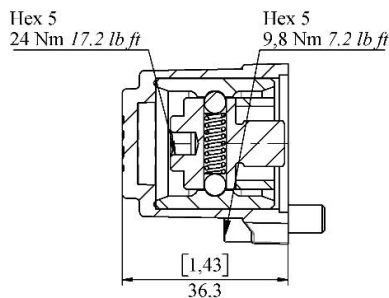
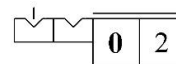

Kit 11

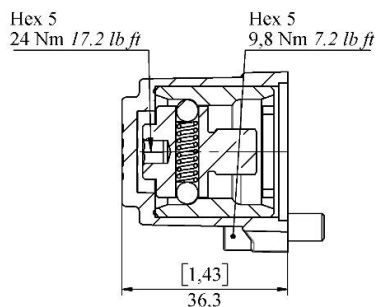
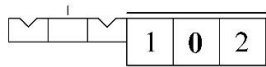

Kit 8F

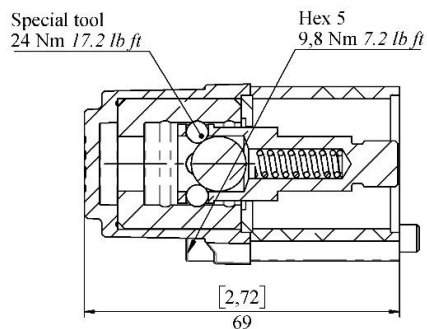
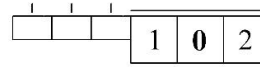

Spool positioners (B-side)

Kit 2: 3 position, spring return from pos. 2 to pos. 0 and detent in pos. 1

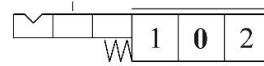
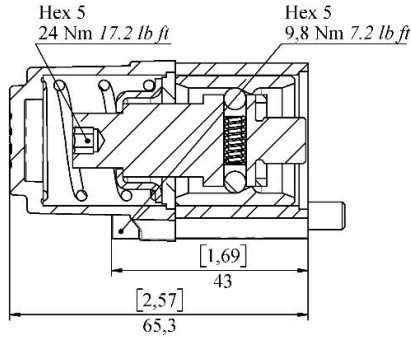

Kit 3: 3 position, spring return from pos. 1 and detent in pos. 2

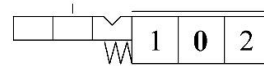
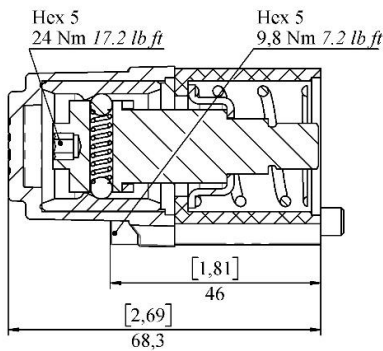

Kit 3D(M8): 3 position, spring return from pos. 1 and detent in pos. 2 and pin with thread M8 for dual control

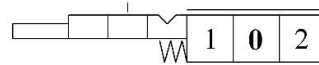
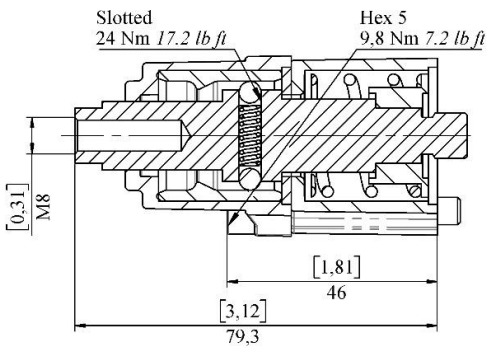

Kit 11B: 2 position, with detent in both positions and spring return to neutral from either direction

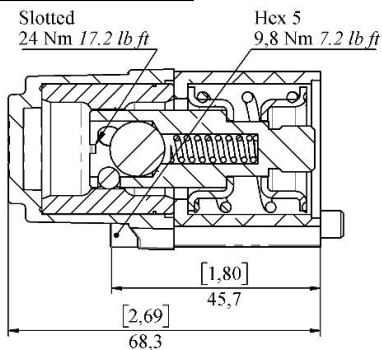

Particular spool positioners kits for microswitch

Kit 1E for double acting spool A or D

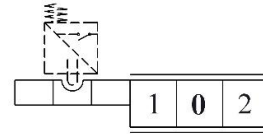
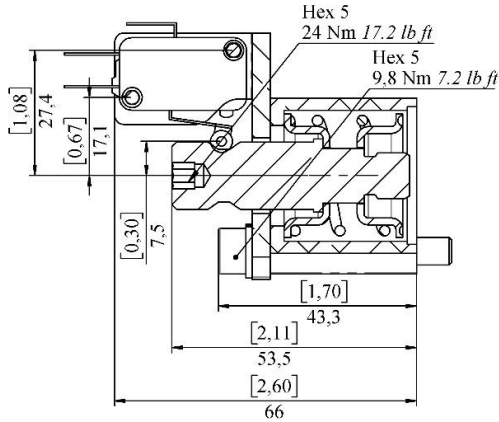

For double acting spool A

Kit 1E for single acting spool B

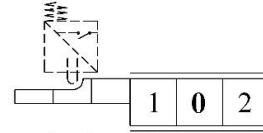
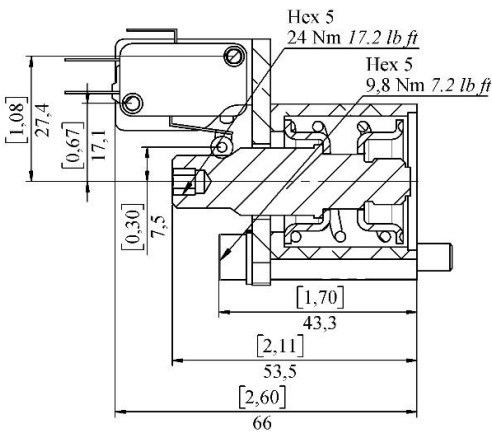

For single acting spool B

Kit 1E for single acting spool C

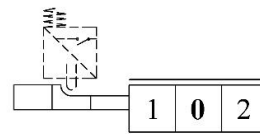
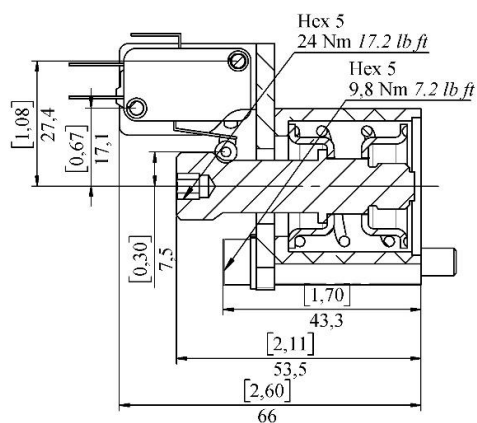

For single acting spool C

Microswitch specification for spool positioner 1E

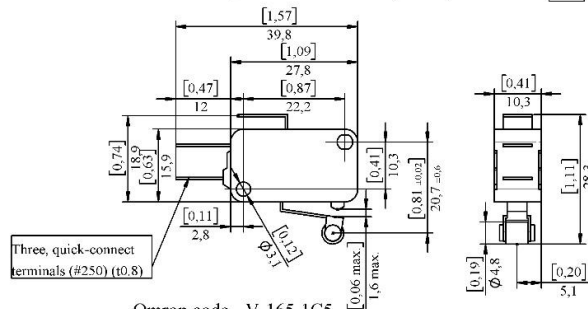

Omron code - V-165-1C5

Needs a special bracket to be assembled with spool positioners

Spool positioner for flexible cable connection (side B)

Kit 1V2

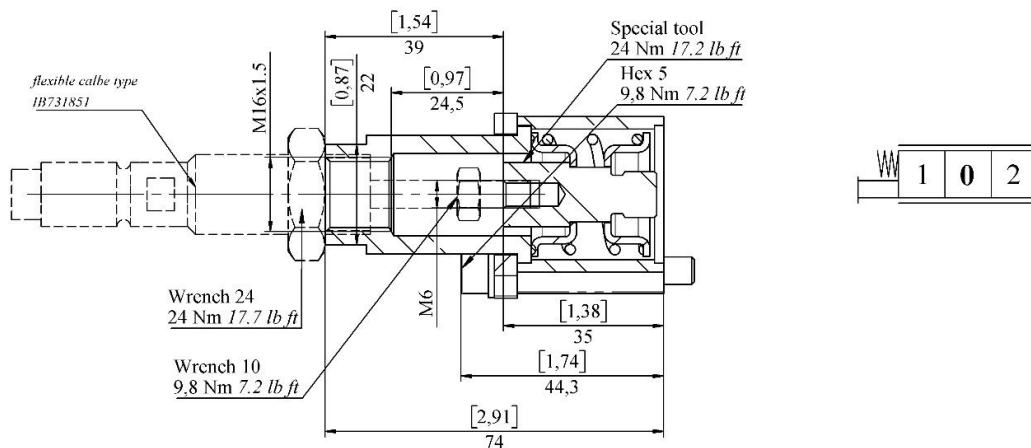

Kit 8V2

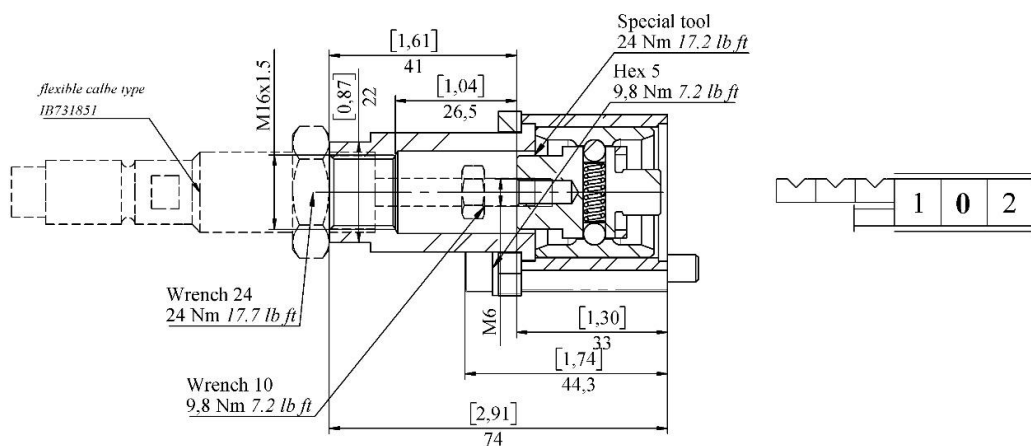

More information regarding controls, cable lengths, and ordering codes see page for flexible cable control V1 (Side A)

ON/OFF Pneumatic kit - 1P

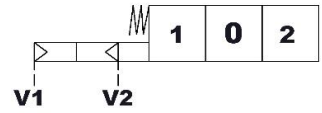
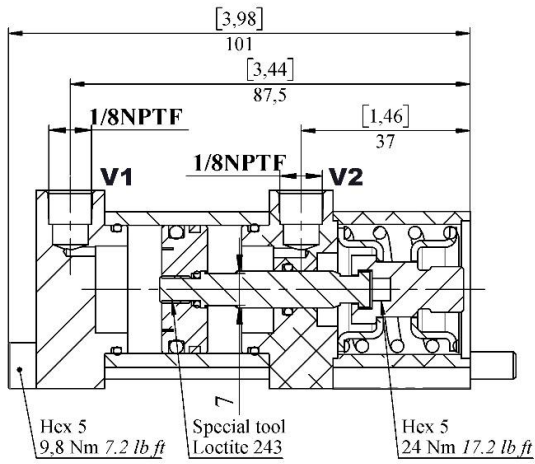

Operating features

Pilot pressure	min	6 bar / 87 psi
	max.	10 bar / 145 psi

ON/OFF Electro pneumatic kit - 1PE

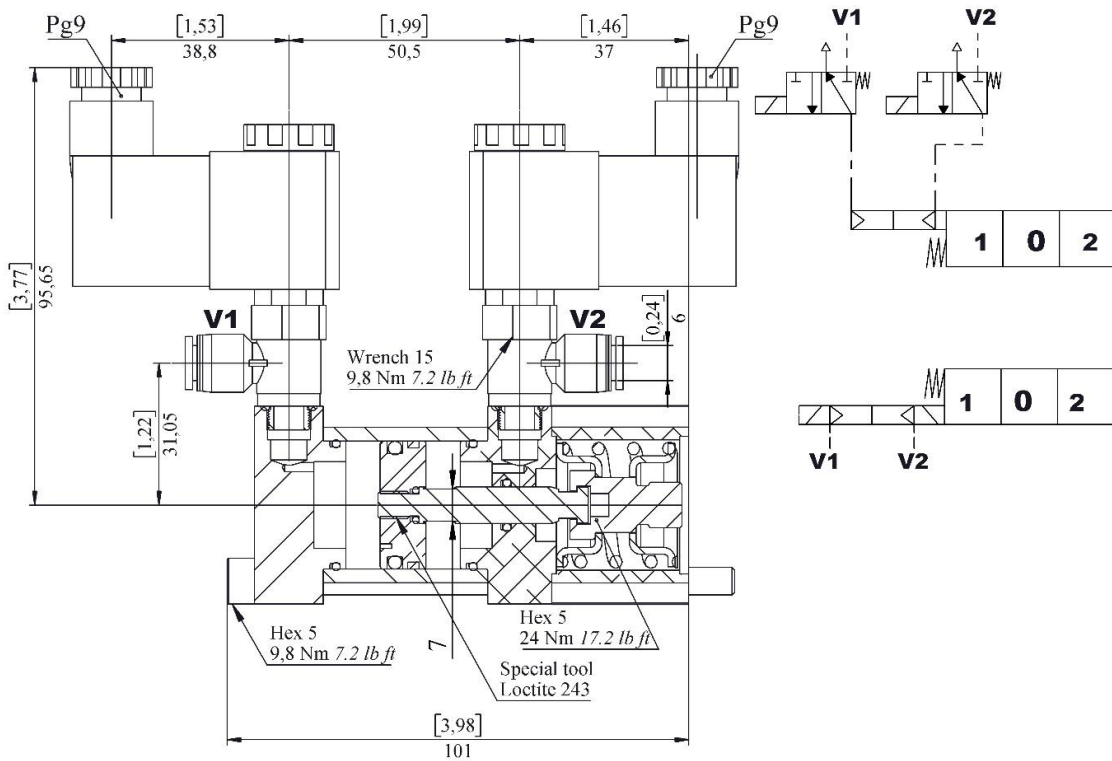

Connector specifications:

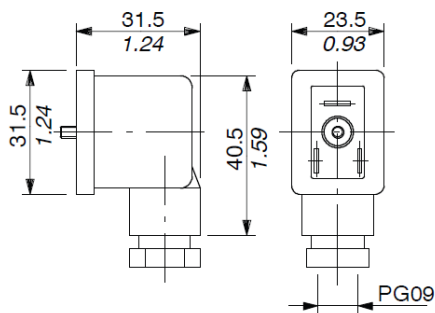

Operating features

Pilot pressure	min	6 bar / 87 psi
	max.	10 bar / 145 psi

COIL specifications

Nominal voltage tolerance	±10 %
Power rating	4,8 W
Nominal current	0,4 A - 12 VDC
	0,2 A - 24 VDC
Coil insulation	Class F
Weather protection	IP65
Duty cycle	100%

Connector is always included in 1EP control

Proportional hydraulic, single side kit - 1H

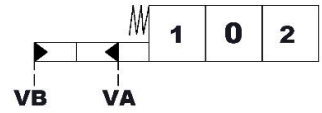
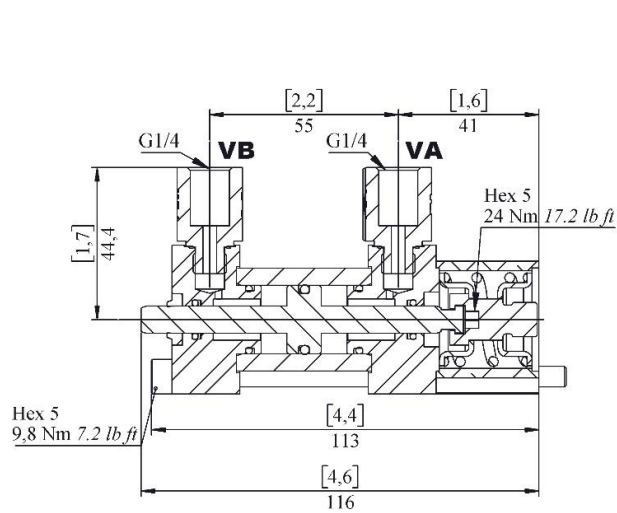

Operating features
Pilot pressure max. 50 bar / 725 psi

Pilot pressure - stroke diagram

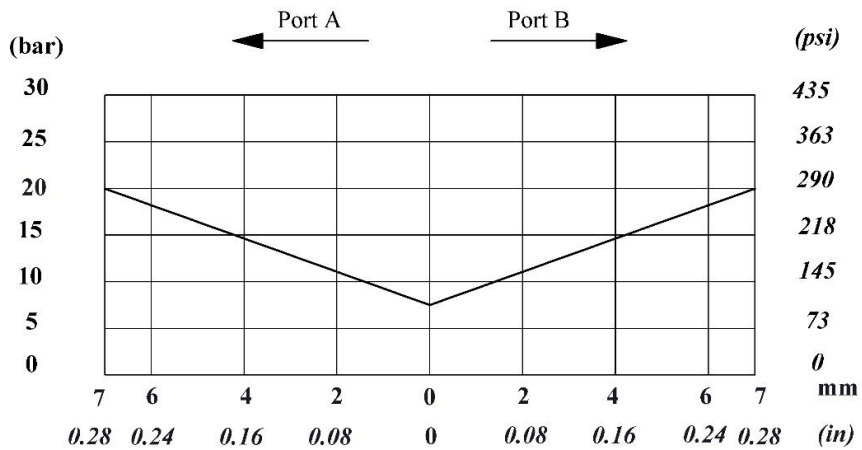

ON/OFF electro-hydraulic kit - 1ED3

With spring return to neutral position

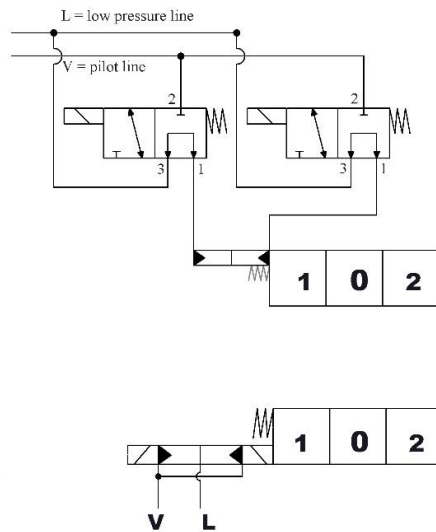
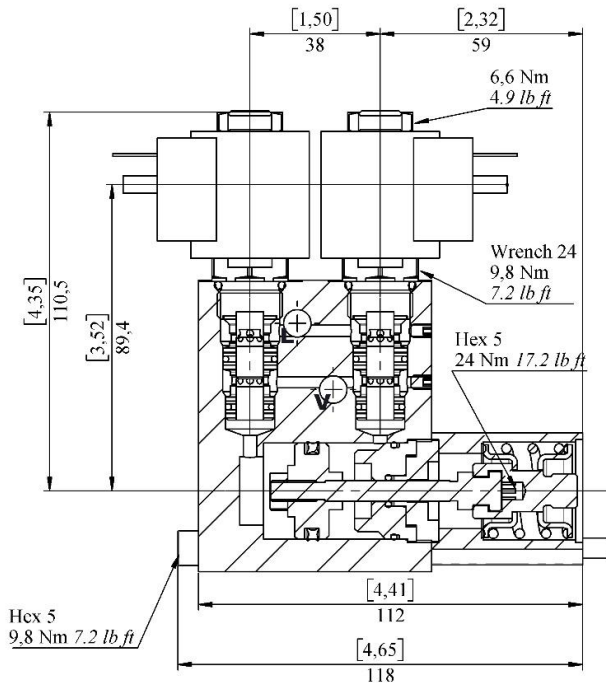

Connector specifications

2 poles, type Deutsch DT06-2S
Male housing with female ends

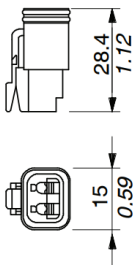

Connector specifications

2P+T according to
ISO 4400 / EN175301-803

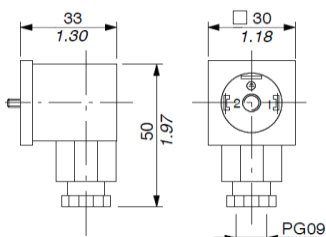

Operating features

Pilot pressure	min	10 bar / 145 psi
	max.	50 bar / 725 psi
Back pressure on drain L	max.	25 bar / 360 psi

COIL specifications

Nominal voltage tolerance	±10 %
Power rating	21 W
Nominal current	1,75 A - 12 VDC
	0,87 A - 24 VDC
Coil insulation	Class F
Weather protection	IP65
Duty cycle	100%

ON/OFF electro-hydraulic kit - 1ED3 with external drain

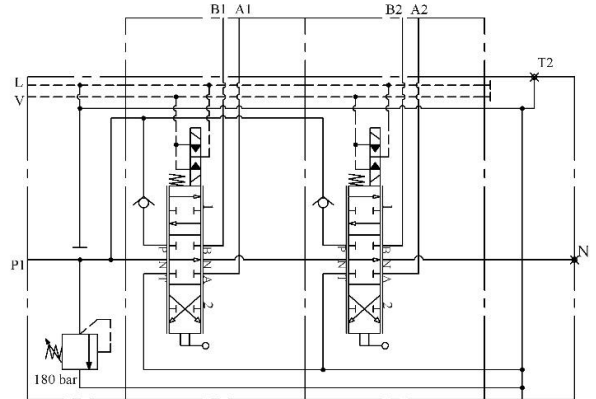
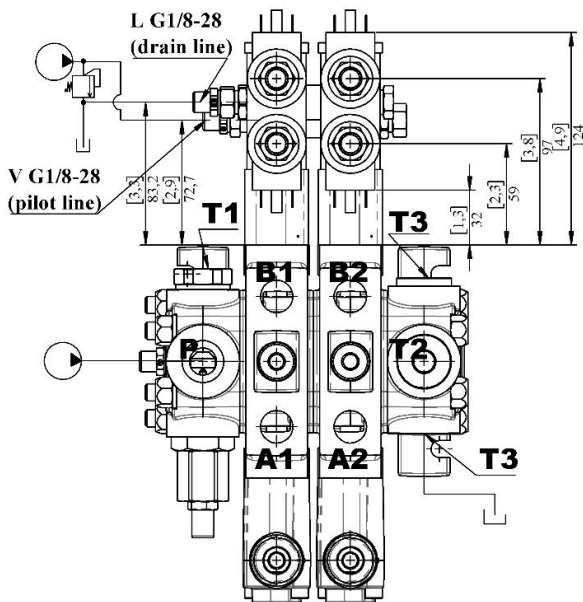

Description example:
2PC70/N2/2x(PA1ED3KZ1)/T3-24V-G34

ON/OFF electro-hydraulic kit - 1ED3 with pilot and drain lines

Kit consists of pressure reducing valve, VRP, back pressure valve VRE and pipes

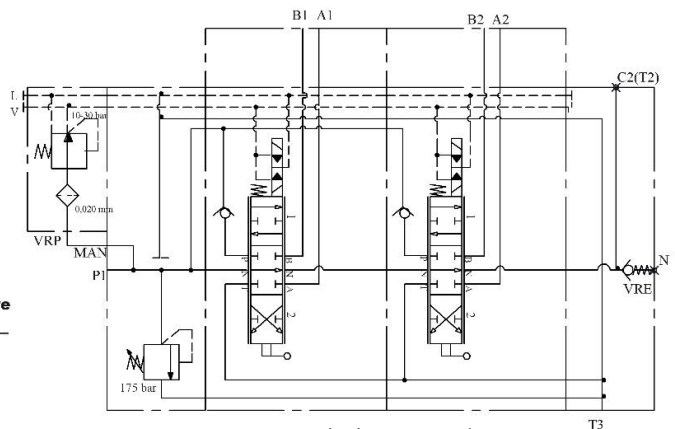
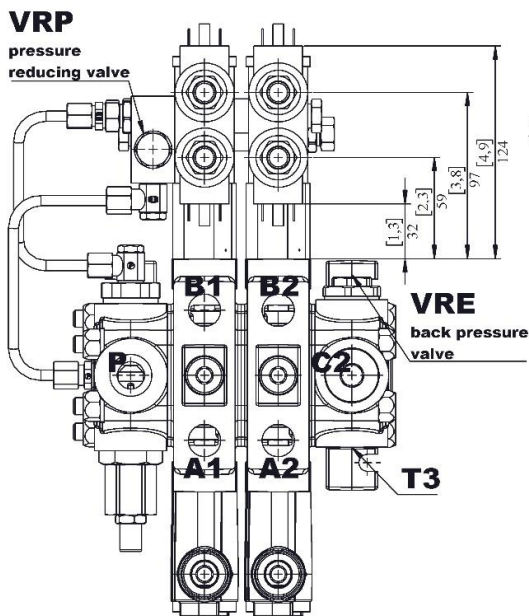

Description example:
2PC70/N2/VRP/2x(PA1ED3KZ1)/T3(VRE)-24V-G34

**Back pressure valve (VRE)
specifications**

Valve is assembled on the bypass flow port N to provide pilot pressure to the actuator

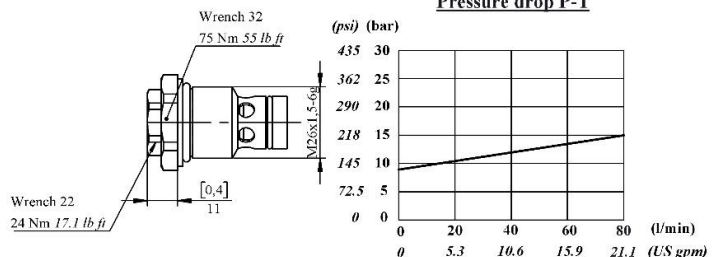

Lever control (Side A) – aluminum cap, with protection booth lever pivot box

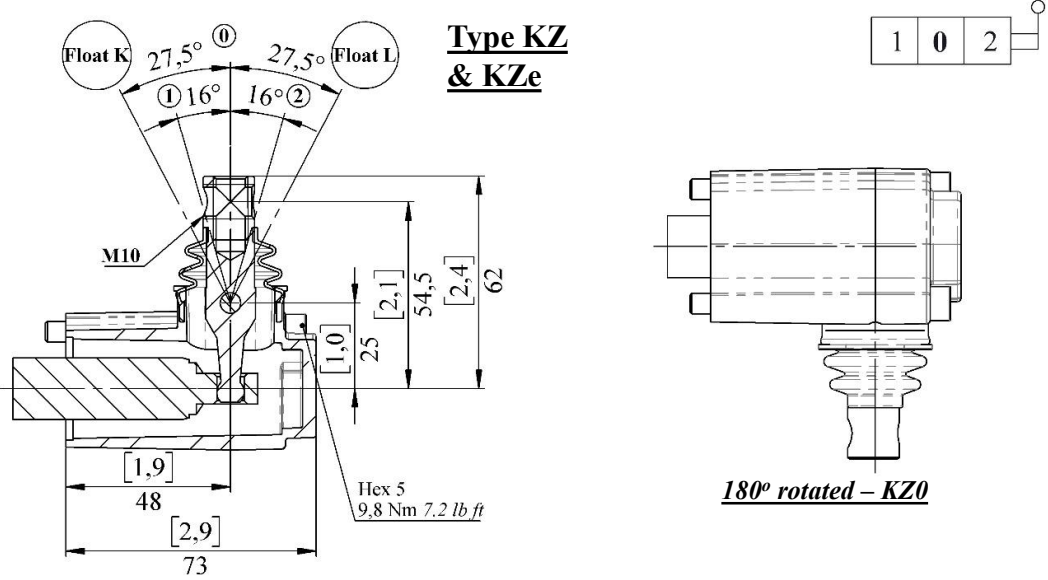

Note: For L spool lever kit KZ, KZe, and KZ0 consists of two part (similar to KZT)

Kit KZT

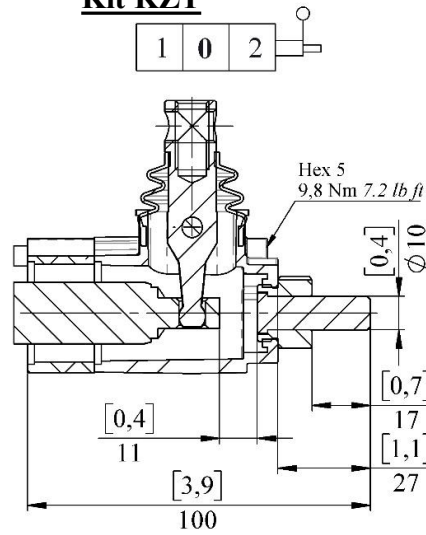

Type KI

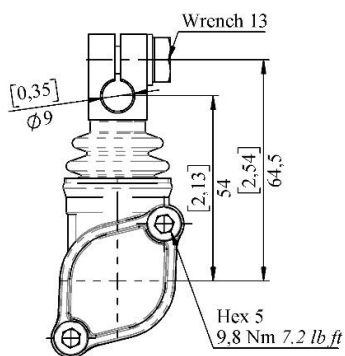

Type KY

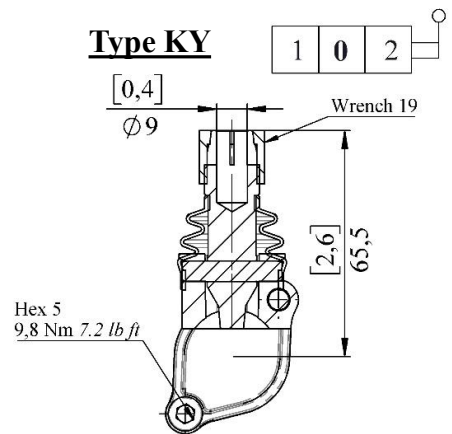

Other control arrangements (side A)

If in the order code side A is left blank, omit control type will be supplied:

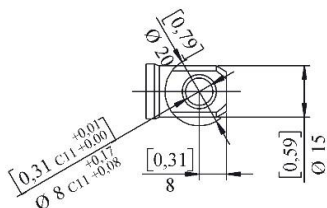
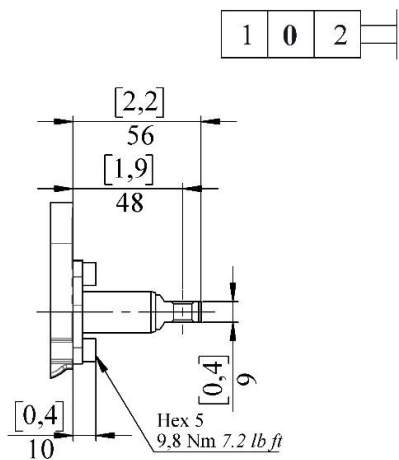

Type SLP

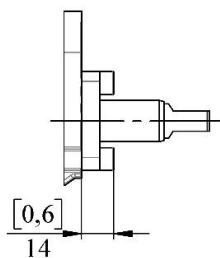

Mechanical control with dust-proof plate

Cable remote control – V1

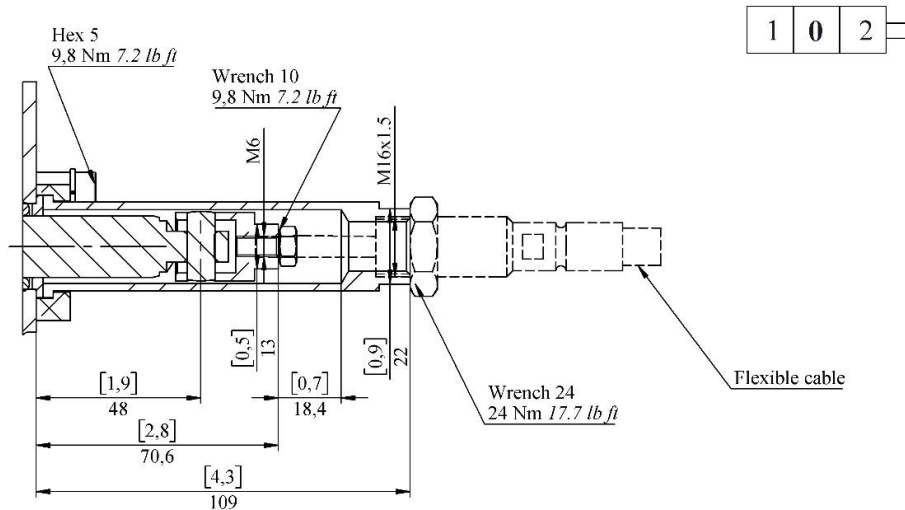

V1 cable remote control for spool L has a particular kit

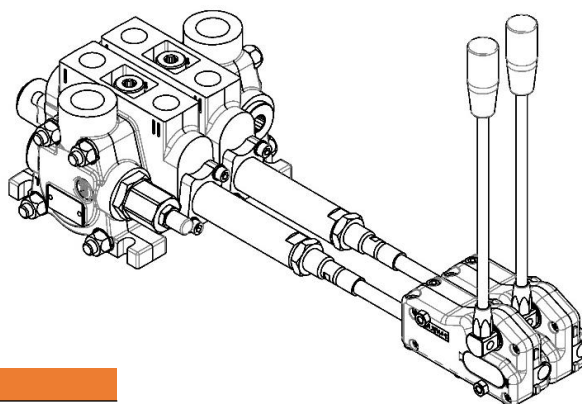

Controls for flexible cables

3335	Mechanical joystick control for 2 spools without buttons
3375	Mechanical joystick control for 2 spools with 1 button
6008	Mechanical joystick control for 2 spools with 2 buttons
IS 3047	Single lever control
IS 3076	Single lever control with antireverse lock

Flexible cable options code + length

IT-731133	1.00 m
IT-731134	1.50 m
IT-731135	2.00 m
IT-731136	2.50 m
IT-731137	3.00 m
IT-731138	3.50 m
IT-731139	4.00 m

Mechanical joystick for two section control

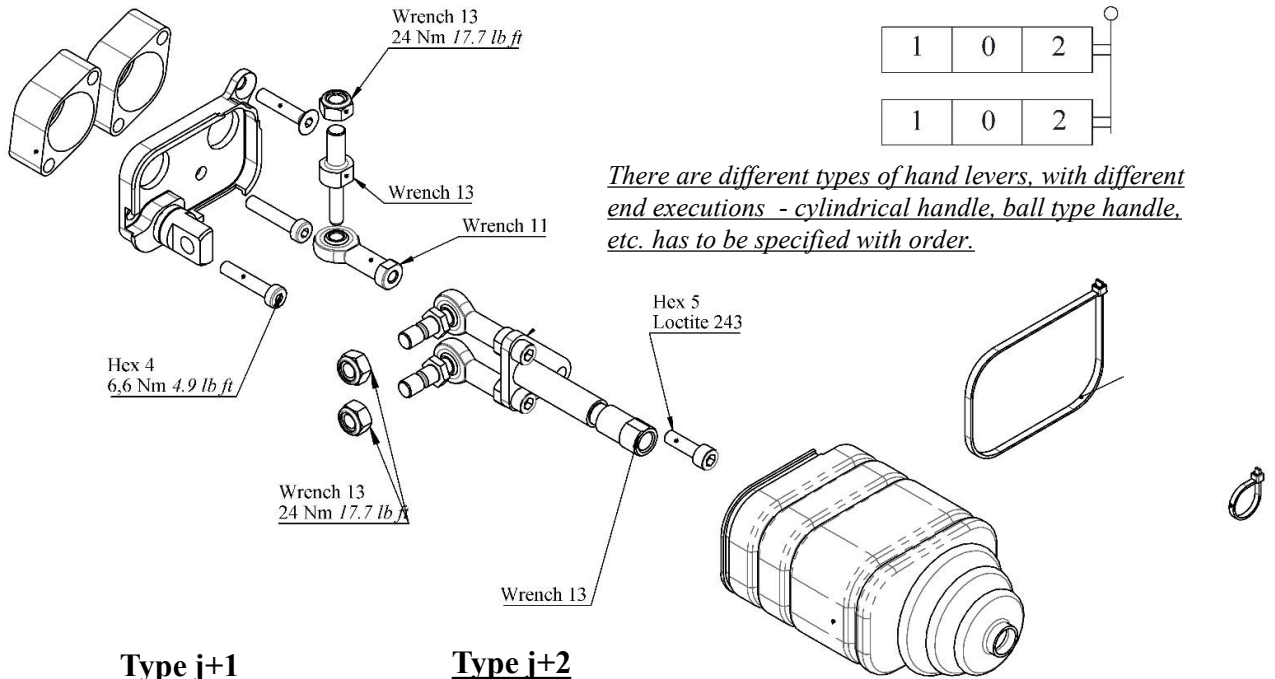

Type j+1

Pivot is above right

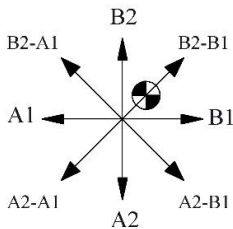

Type j+2

Pivot is above left

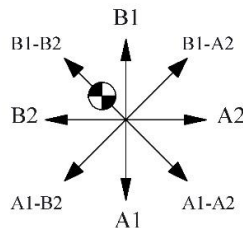

Type j+3

Pivot is bottom left

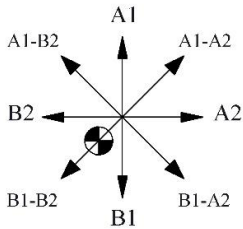

Type j+4

Pivot is bottom right

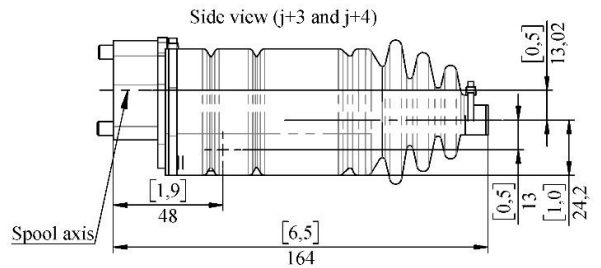
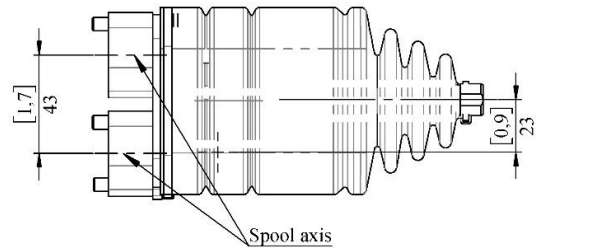
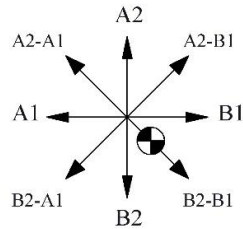

Standard hand lever dimensions

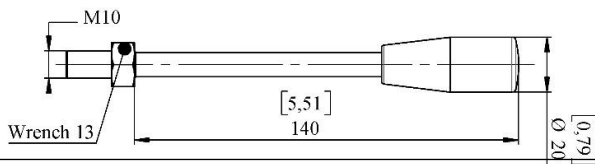

Example description with standard lever:
2PC70N2/(PA1.PA1(AzBz))(ju+3)/T
2-G34 or another possible description:
2PC70N2/(2x(PA1(AoBo)))(ju+3)/T
2-G34

Complete control – proportional hydraulic control H3

It can be used with standard spools, without seals on the spools; can be used only with P and T sections.

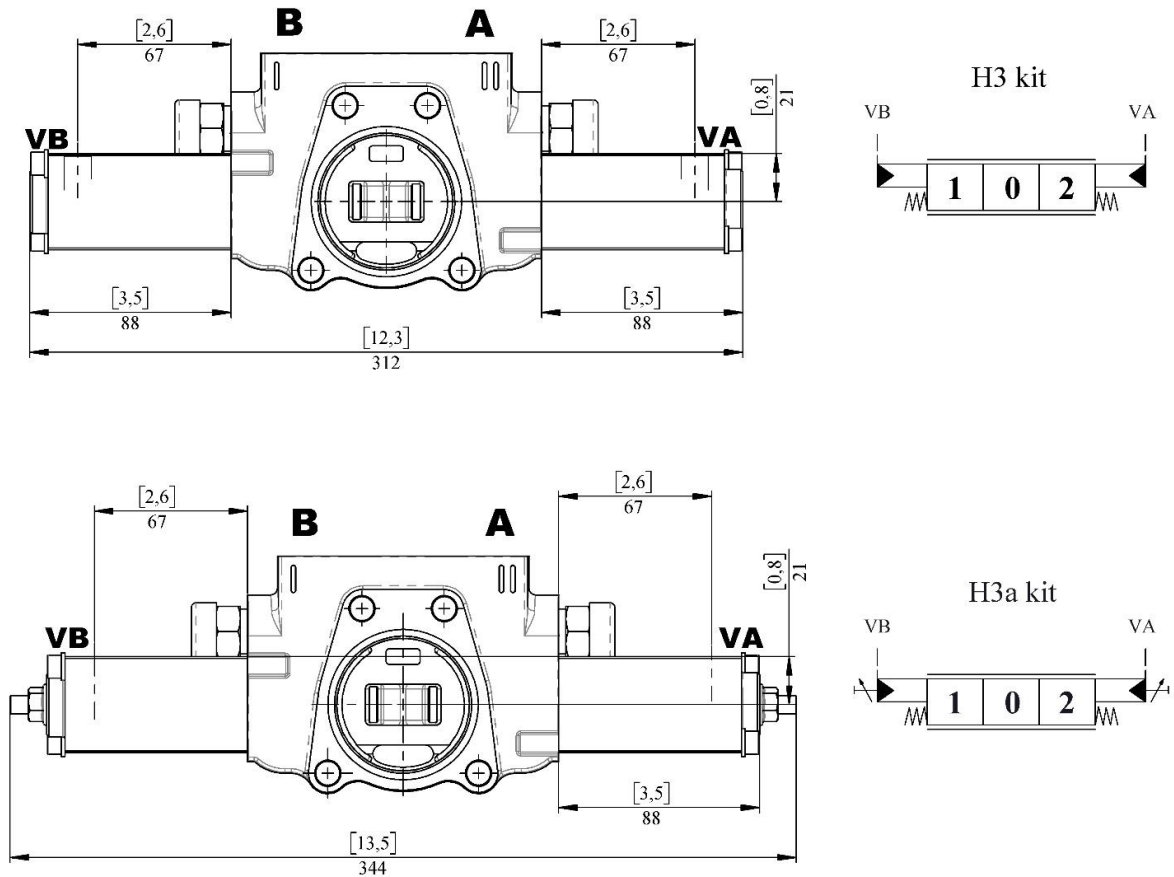

Pilot pressure - stroke diagram

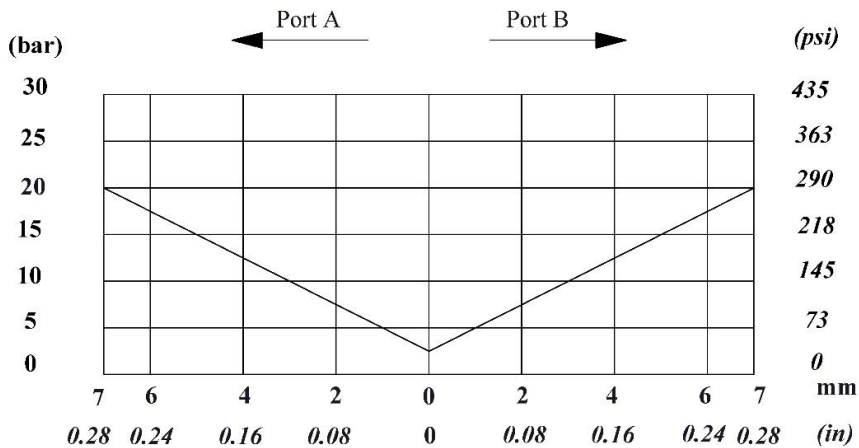

Max. pilot pressure....30 bar

Port valves

Y-type anti-shock valves

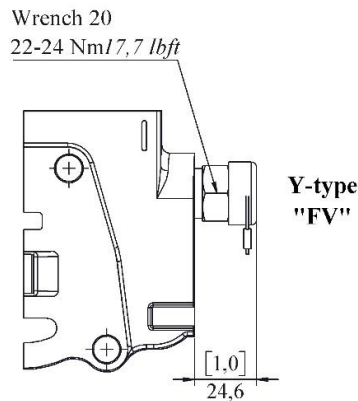
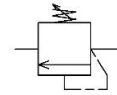
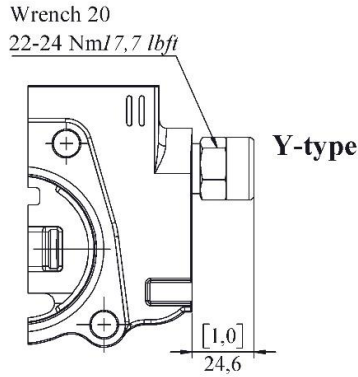

Spring D2: Range 50 - 120 bar / 725 psi to 1740 psi, standard setting at 125 bar / 1740 psi

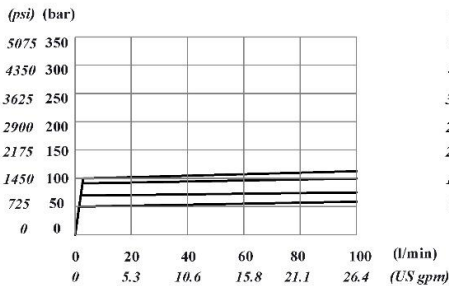

Standard spring (no name): Range 120 - 250 bar / 1740 psi to 3625 psi, standard setting at 180 bar / 2610 psi

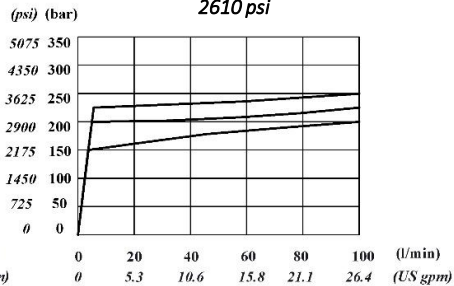

Spring D4: Range 220-315 bar / 3190 psi to 4570 psi, standard setting at 220 bar / 3190 psi

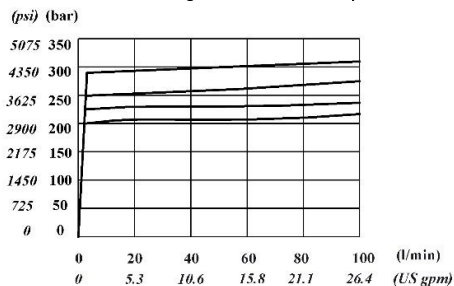

Port valves

Z-type anti-shock and anti-cavitation valves

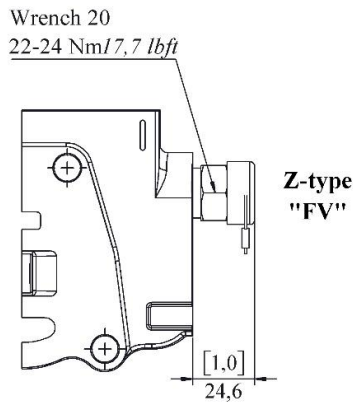
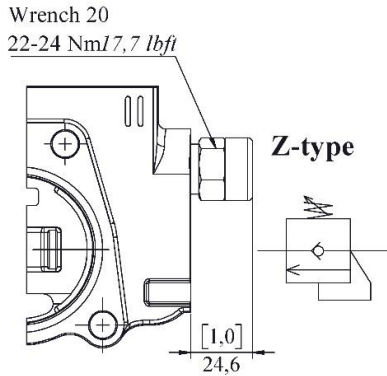

Spring D2: Range 50 - 120 bar / 725 psi to 1740 psi, standard setting at 125 bar / 1740 psi

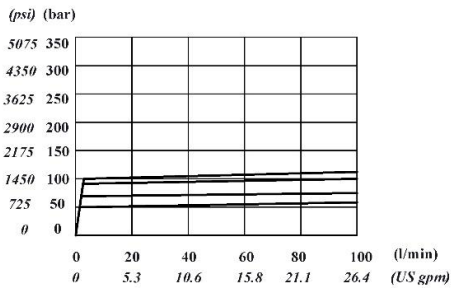

Standard spring (no name): Range 120 - 250 bar / 1740 psi to 3625 psi, standard setting at 180 bar / 2610 psi

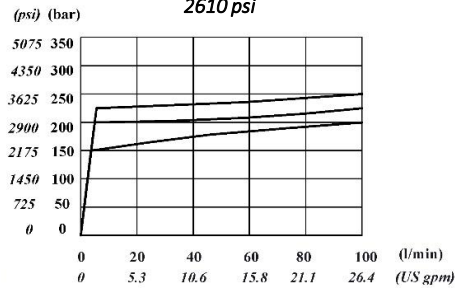

Spring D4: Range 220-315 bar / 3190 psi to 4570 psi, standard setting at 220 bar / 3190 psi

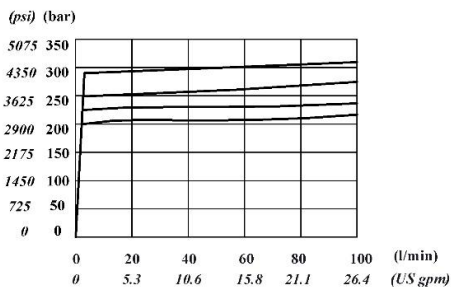

Pressure drop through anti-cavitation valve

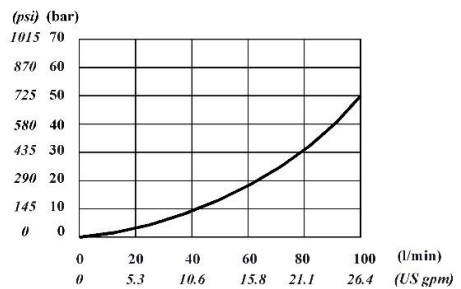

Port valves

Anti-cavitation valve

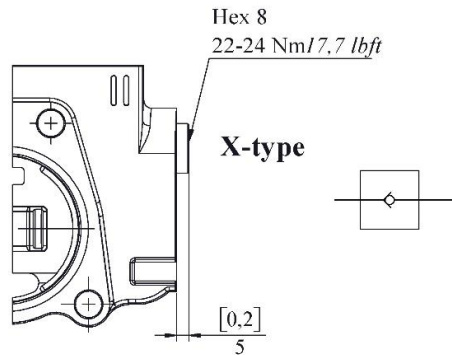

Pressure drop through anti-cavitation valve

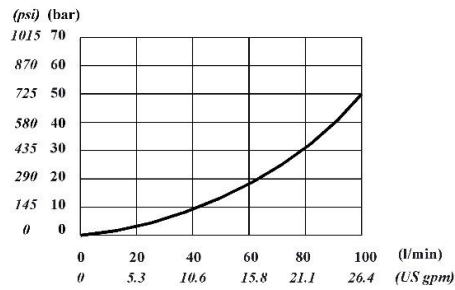

Valve blanking plug

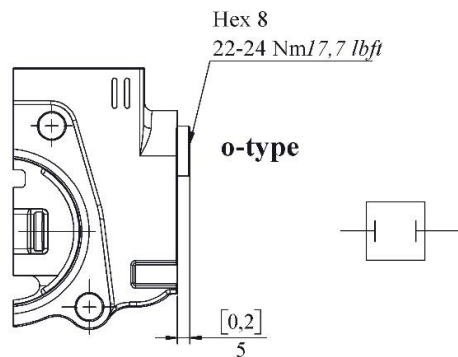

Middle covers

DF pressure compensate flow divider section

The flow on the downstream sections can be adjusted from 0 to 80 l/min 21 US gpm by means of graduated handwheel; exceeding flow goes to tank.

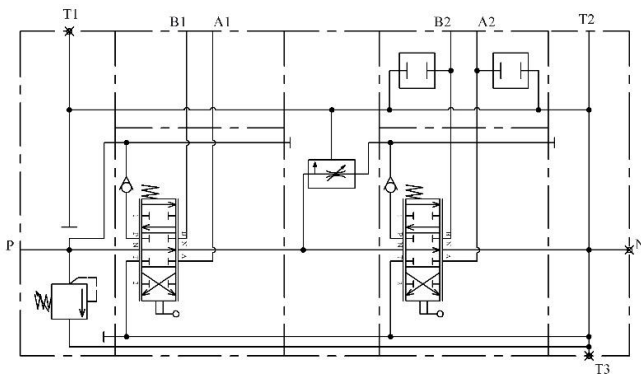
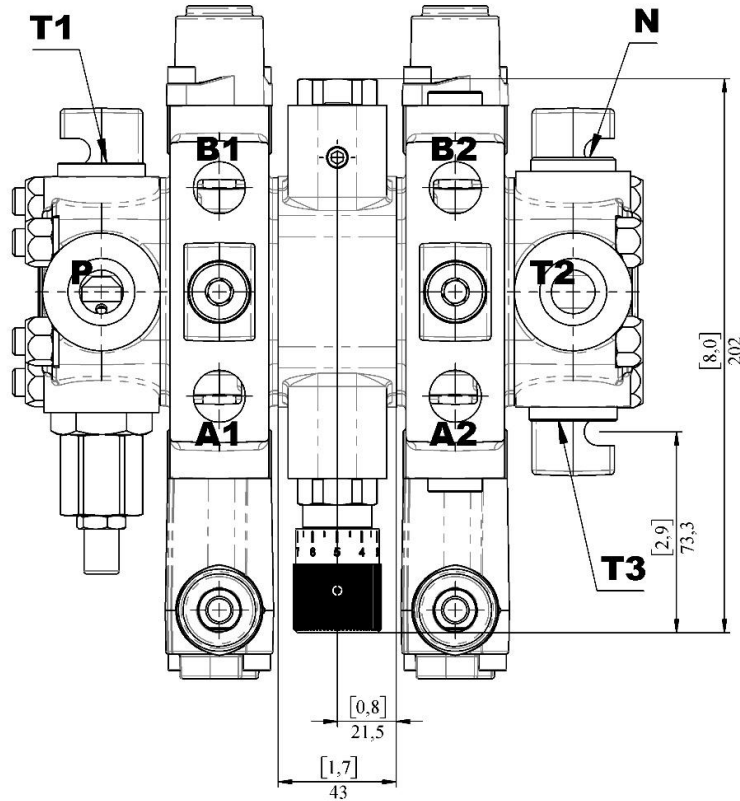

Description example:
2PC70/N2/PA1KZ1/DF/PA1KZ1(AoBo)/T2-G34

Flow regulation diagram

P=100 bar 1450 psi

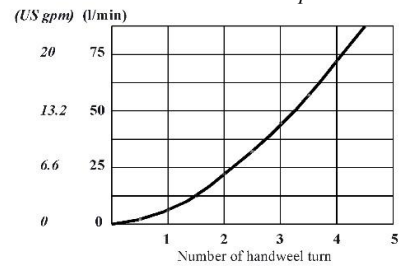

Pressure-flow diagram

Q=90 l/min 24 US gpm



Middle covers

IM.C Middle inlet section adding a second flow to the sections downstream

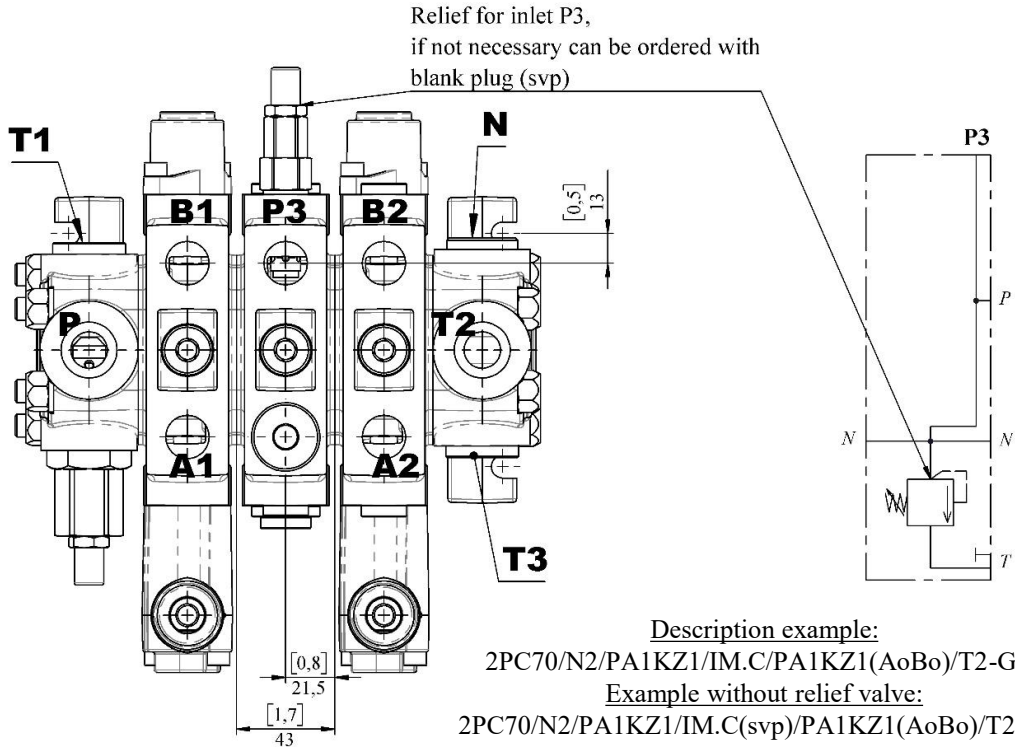

IM.S Middle inlet section interrupting the flow from inlet cover and providing a separate flow to the sections downstream

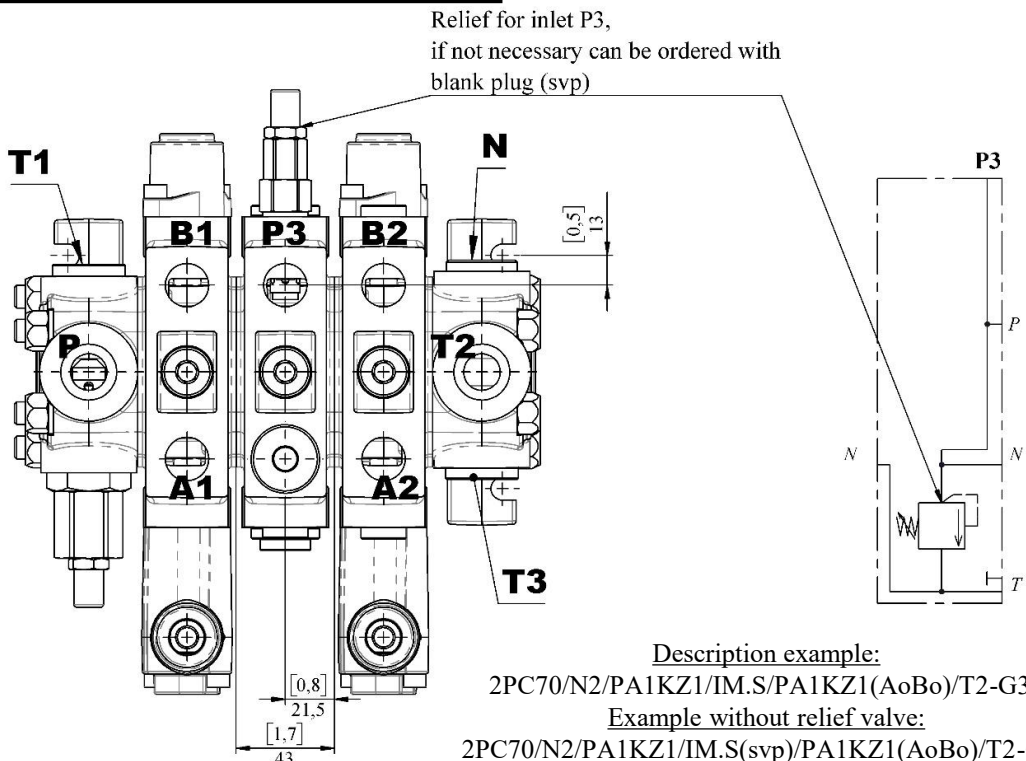

Middle covers

OM.C2T Middle outlet section with high pressure line and tank line for dual inlet cover schematic

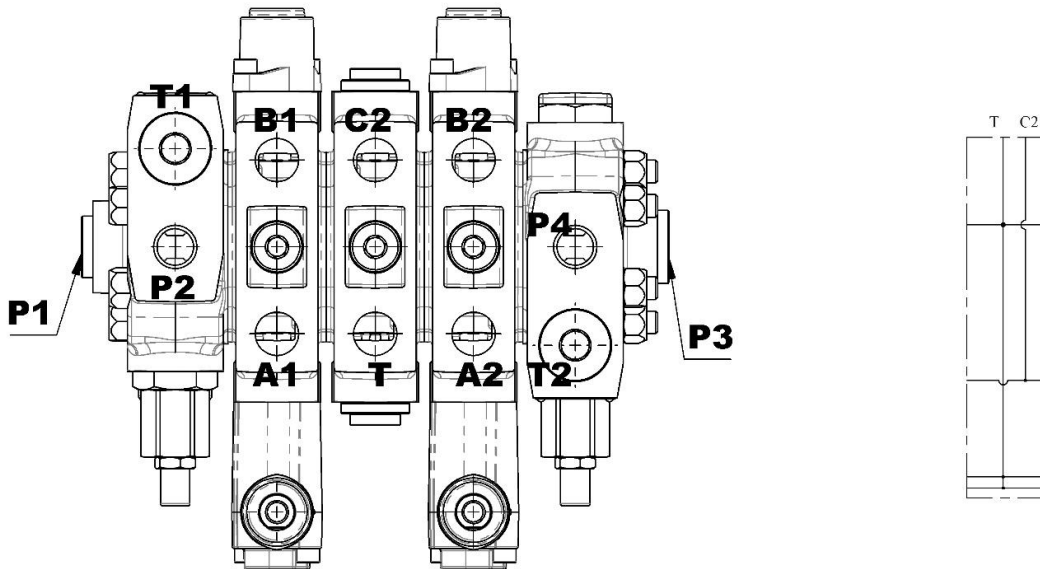

Description example:
2PC70/L2/PD1KZ1/OM.C2T/PRD1KZ1/L4-G34

OM.C2TC2R Middle outlet section with dual high-pressure lines for dual inlet cover schematic and use of T1

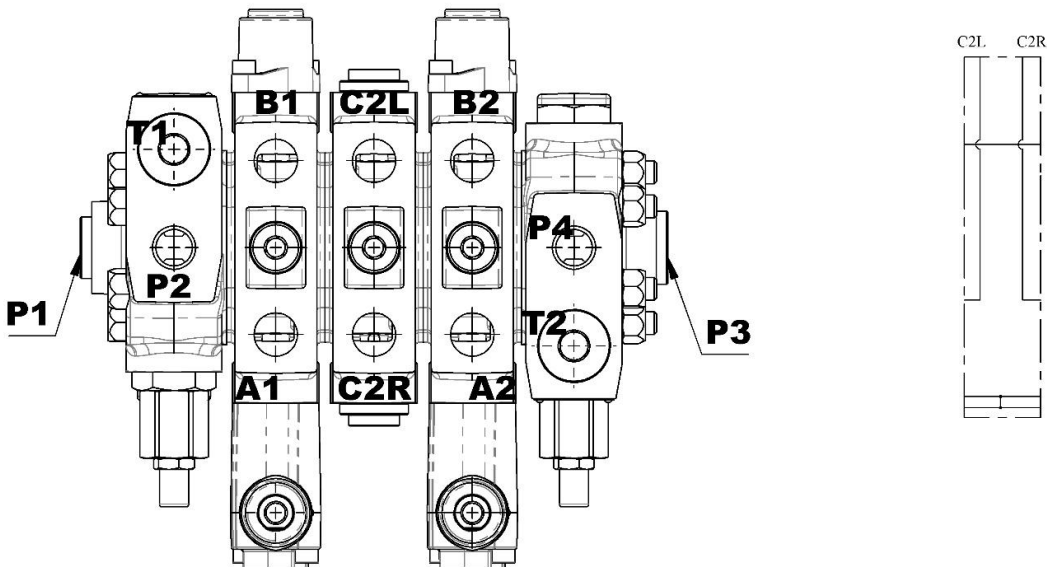

Description example:
2PC70/L2/PD1KZ1/OM.C2L.C2R/PRD1KZ1/L4-G34

Middle covers

CS Middle outlet section with two additional outlet ports T4, and T5

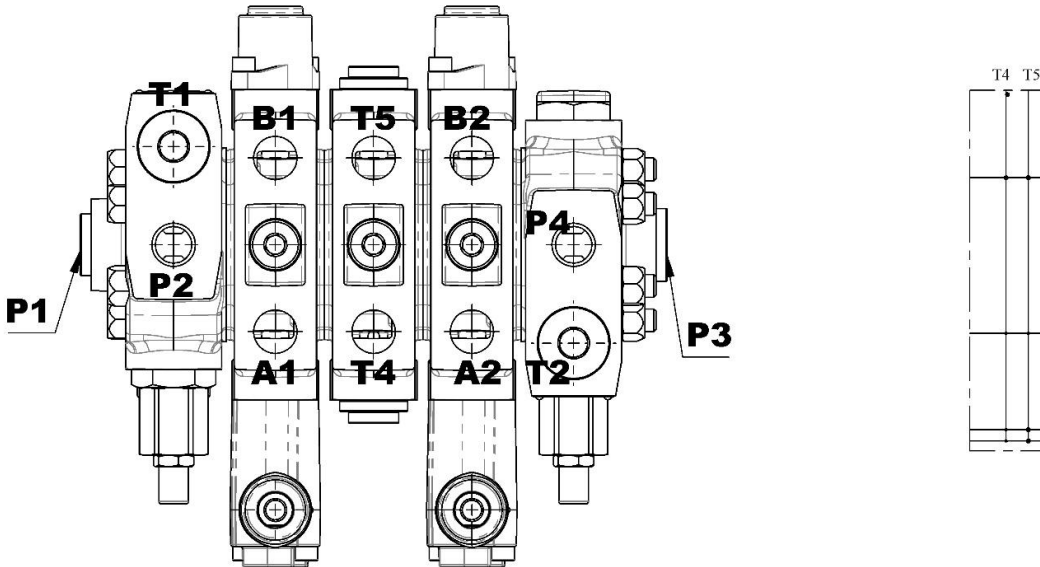

Description example:
2PC70/L2/PD1KZ1/CS/PRD1KZ1/L4-G34

Outlet cover

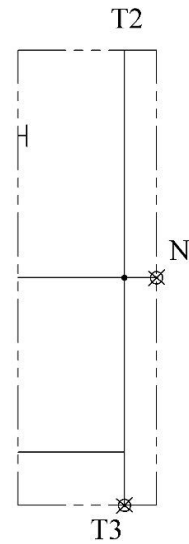
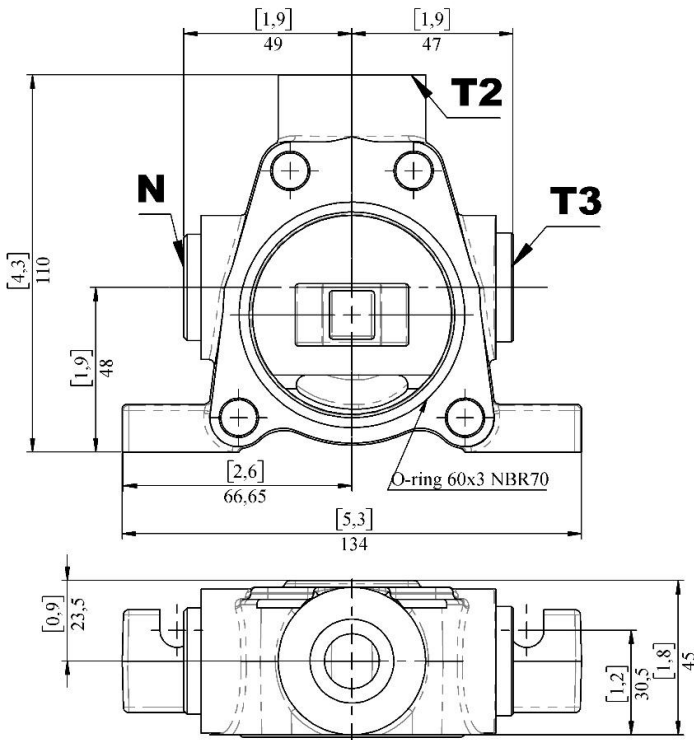

Description example:
T2-G34

Outlet cover with tank port on the inlet cover (T1)

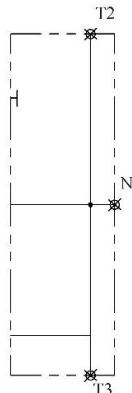
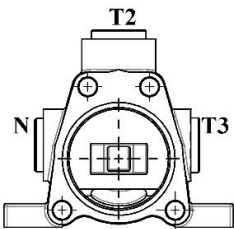

Description example:
T1-G34

Outlet cover with HPCO C2 and tank port on the inlet cover (T1)

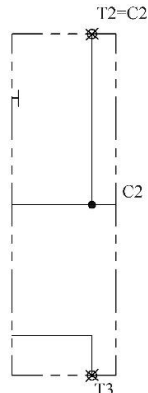
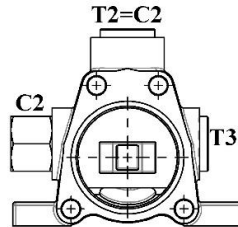

Description example:
T1-C2-G34

Outlet cover with HPCO C2 and tank port T3

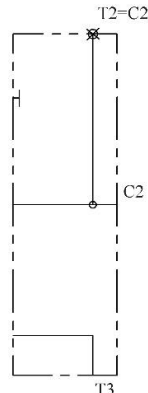
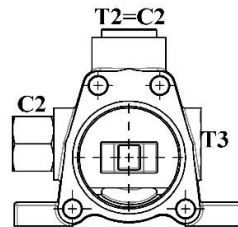

Description example:
T3-C2-G34

Outlet cover with VRE (back pressure valve for ED3 control) and tank port T3

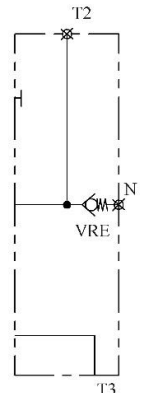
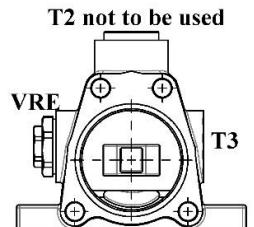

Description example:
T3(VRE)-G34

Note: Closed centre system can be achieved by plugging C2 port with standard plug

