

NEW FLOATING SPOOL AND SPOOL POSITIONER for P120

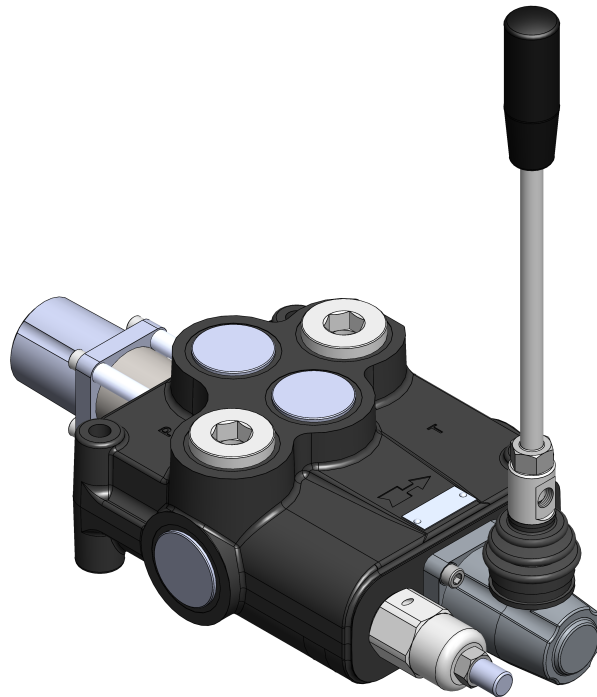

Technical specification		
Flow rate	l/min [gpm]	120 [32]
Max. pressure on A&B	bar [psi]	300 [4350]
Leakage (A,B to T) at 100 bar [1450 psi] and 46 cSt	cm ³ /min [in ³ /min]	6 [0.37]
Operating pressure	bar [psi]	10 to 50 [145 to 725]
Max. pressure in L	bar [psi]	25 [363]
Additionally machined body of P120		

Sample order code:
P120/L12/G/KZ1/*

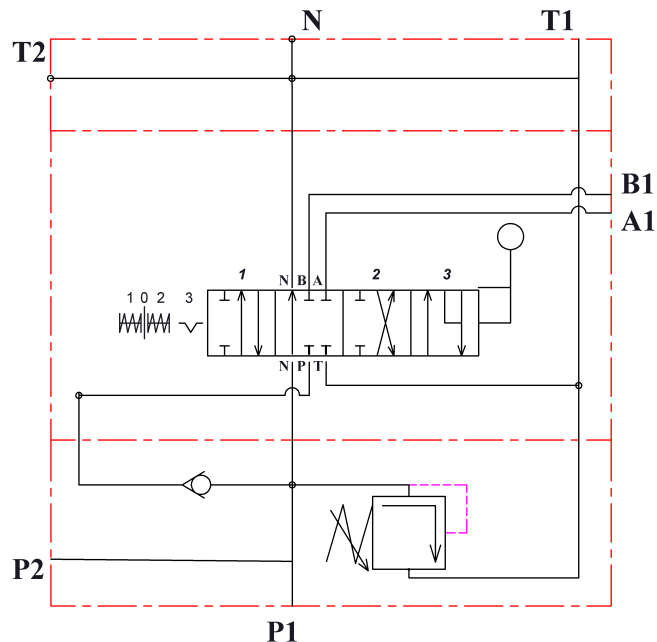

* The body is specially machined, therefore normal spools A, B, cannot be used!